



***INSTALLATION, SERVICE
AND MAINTENANCE
INSTRUCTIONS***

***Gas Pressure Regulators
of Two-Stage Regulation
Type : RTP .. - M.. - ..***

REGADA

REGADA, s. r. o., Strojnícka 7
080 01 Prešov, Slovak republic
Tel.: +421 51 7480465, 7480464
Fax: +421 51 7480466

75 0600 04

1 Application

The gas pressure regulators (RTP) are designed for decreasing of natural gas pressure from medium to the low one and keeping the output gas pressure rate in the specified range independently on inlet pressure and flow changes. They are suitable for use in domestic gas installations.

2 Operating description

The two-stage gas pressure regulators have got two stages of pressure reduction, both with diaphragm-spring control to assure constant output pressure not depending on any changes of inlet pressure and flow. The RTP is equipped with the following safety devices:

- High pressure and low pressure safety shut-off device (SSD)
- Relief valve (RV) for relieving gas into atmosphere

In case of outlet pressure raise over the adjusted value the high pressure device closes the regulator gas pressure inlet. The pressure raise can lead from seat untightness (wear, dirt, ice).

In case of outlet pressure drop under the adjusted value the low pressure device closes the regulator gas pressure inlet. The pressure drop can arise from decrease of pressure on the regulator inlet or from overflow. The device (SSD) closes the gas way through the regulator also in the case when the current flow rate is over an adjusted regulator maximum flow rate (in range from 1,1 to 1,5 Q_{max}).

After the regulator is closed by the SSD it can be put into operation only after a service man intervention.

The relief valve prevents the output pressure against raising with relieving gas into atmosphere in case of higher pressure. Its operation is automotive and does not require any intervention.

The regulators are manufactured of various versions (direct, angle, various size of nuts) for mounting into output piping.

The RTP regulators are in the plant adjusted to the values according to corresponding standards. Any access to adjusters is protected against unauthorised manipulation. The RTP regulators can be adjusted to other values than stated here. The adjusted consumption pressure and safety devices are in the plant checked on all regulators.

3 Specifications of RTP according to EN 12279

Parameter	Unit	RTP 3-M...-	RTP 6-M...-	RTP 10-M...-
Inlet Pressure Range p_v	^{1) 5)} MPa	0,05 až 0,5		0,1 až 0,5
Outlet Pressure p_s	¹⁾ kPa	2		
Accuracy Class	%	AC 5		
Closing Pressure p_u	¹⁾ kPa	max. 2,6		
Relief Pressure p_p	¹⁾ kPa	3 ± 0,1		
Shut-off Pressure p_{bmax}	¹⁾ kPa	4,5		
Shut-off Pressure p_{bmin}	¹⁾ kPa	1		
Regulator Flow capacity (Q_v)	²⁾ m ³ /h	3,5	6	10
Maximum Flow (Q_{max})	²⁾ m ³ /h	3,5	6	10
Relief hole VENT	⁴⁾ inch	R _o 3/8		
Weight	kg	1,12		
Ambient Temperature Range	³⁾ °C	-30 to +60		

¹⁾ Manometric pressure

²⁾ Natural gas (0,72 kg/m³, 15 °C, 101 325 Pa)

³⁾ Valid for dry gas. For wet gas +1 °C to +60 °C

⁴⁾ The thread is not delivered as a standard, necessary to place the requirement in the order

⁵⁾ The regulator can function also at lower inlet pressure from 0,01 MPa (0,01MPa = 10 kPa), then flow rate can be read from regulator capacity curves.

Basic specifications, the kind of gas and Serial No. are stated on the nameplate placed on the regulator's body.

12 The attestation of article quality and entirety

Name and Type of Product	Gas Pressure Regulator
Serial Number	
Standard	EN 12 279
Technical Parameters	TP 75 0283/98a
Date of production	
Output check	

13 Record about Installation and Inspections

Installation – date, name, sign and stamp of installing organisation		
Date	Inspection description, repairs	Sign and stamp

In case the flow outlet of the regulator is decreased it is needed to replace the screen built into the inlet. The procedure for the screen replacing:

- close the shut-off valve before the regulator, disconnect the inlet,
- dismantle and remove the screen, install a new screen,
- connect the inlet with the piping,
- open the shut-off valve before the inlet and check tightness of connections,
- put the regulator into operation with the procedure described in the part Operation.

8 Control and Maintenance

Control is carried out in the built-in regulator. The results should be written down into the part Record about Installation and Inspections. In the case the control results are not correct it is necessary to send the regulator to the service.

In case of standard operation conditions during the whole live the regulators does not require any maintenance.

Controlled measure procedure:

- to close both the inlet and outlet closures ,
- to screw off the blind bolt in the outlet piping and screw the connection of the outer pressure source with control manometer ,
- to put RTP into operation according to the instruction described in the part Operation ,
- to control outlet pressure at the nominal flow (devices-on) and at the zero flow ,
- to check both relief valve (RV) and diaphragm tightness at the zero flow (e. g. by foam liquid) ,
- to close the inlet closure and open outlet closure slowly, check the outlet pressure when closed shut-off device (SSD) - parameter point p_{bmin} ,

to put RTP into operation according to the instructions in the part Operation, to close the outlet closure, to lead the pressure under the regulation diaphragm from outer source and check the relief valve (RV) function. Gas escape has to be found out at the venting hole if the pressure is higher than parameter point p_p - Must be ensured gas escape from under the plastic cap on the regulating chamber RTP (black plastic cover of relief hole on relief valve on the opposite side of the regulator like the cover with control element, according fig.)

- to control shut-off device (SSD) – parameter point p_{bmax} by increasing the pressure over the setting value p_{bmax} . After the closure of the SSD to screw off the manometer and to verify the shut-off device tightness,
- to blind the hole and put the RTP into operation according to the instructions described in the part Operation ,
- to check outer tightness of the RTP.

Note : For the control measurement of setup p_{bmax} closing pressure it is necessary to close relief hole on relief valve that it had not forgiven the increase of air pressure above the value of the p_p and thereby doesn't reduce the value of the supplied external source of air pressure. Close hole after as much as opening of BU and setting of consumed pressure at the output and before pressure increasing from an external source to output. Relief hole sealing can be done by hand pushing to the plastic cover towards the cap of regulator chamber.

9 Guarantee and Service

The manufacturer is responsible for the regulator properties during 24 months since delivery. In case of any claim it is required to present the gas pressure regulator , a document about buying (payment receipt) and this Installation, Service and Maintenance Instructions. The guarantee is not approved if the damages are caused by inappropriate impact to the regulator or with not following these Instructions .

Under-and-out-of –guarantee repairs can be performed by the manufactures

10 Attention

The gas pressure regulators come under group of gas equipment for decreasing of gas pressure with inlet gas pressure up to and including 0,5 MPa.

Workers performing installation, service, inspection and maintenance has to be skilled by relevant statutes.

11 Product liquidation

Components and pack can be used as source of secondary raw material.
Product is not source of environmental pollution and doesn't include danger scrap.

Edition: 04/2011 Design and dimension can be changed without any notice Document number 75 0600 04

4 Delivery Conditions

The regulators are delivered assembled and with adjusted parameters rates. The adjusters are protected against any access with a seal. The undisturbed seals are conditional to have a right for a guarantee repair. Each regulator has got its Quality and Completeness Certificate which is to be used as a guarantee letter. The regulator is packed in a polypropylene bag and a carton box. Inlet and outlet holes are to be imbedded by flat packing which is packed in box.

The regulator is provided either with direct or angle kinds of arrangement of inlet and outlet holes (see Fig.) The regulators are delivered with mounted coupling nut connection. The regulators can be delivered with other connection (flanges, external thread and others).Dimensions of regulator with coupling nut connection are stated in figure.

5 Installation

For placing and mounting of RTP EN 12 279 are valid if not stated else in the order.

The RTP can be placed in any position. For fixing to a frame the M8 thread holes on the body can be used. Basic position it is with vertical regulation diaphragm (see figure). Other positions are to be consulted with producer or supplier.

While mounting take care to the right flow direction through RTP, which is marked by an arrow on the body. Before mounting remove the plastics caps from the inlet and outlet holes and dirt and water from piping.

In case of types with thread connection an pipe coupling with external cone thread is used (R1/2 inlet and R3/4 outlet). The thread width is to meet ISO 7-1 requirements.

Hemp is not recommended as a sealing. For tightening of connection is to be recommended to use jointing compound (LOCTITE 577 or SISEAL). Types with a coupling nut the torque needed to tighten the G 3/4 nut is of 40 Nm and for the G 5/4 nut it is of 60 Nm.

The regulators can be placed into buildings as well as out of them. While installing into a building the relief hole (VENT) – only based on special order - is to be connected with a piping with DN more than 10 mm. The relief piping is not to be blinded. In case of an external installation the RTP are to be protected against weather influences (rain, wind, snow, sunlight). The RTP are to be placed with an easy access to the safety shut-off device adjuster (see pos. 1, fig.).

The gas shut-off valve is to be mounted before the RTP. The RTP itself is not allowed to be used as a gas shut-off. To be put into operation the RTP does not require placement of any shut-off valve behind it. The RTP is equipped with a screen. In case of remarkable gas contamination it is recommended to mount a filter before the RTP.

The RTP..-MZ-P can be installed also to an underground module, the regulator is provided as waterproof.

6 Operation

After mounting or after the regulator is closed a qualified person is to follow these steps to put it into operation:

First tight the safety device (SSD) (see pos. 1, fig.) up to the stop. Then slowly open the shut-off valve before the regulator. Keep it in the position for about 5 s until the outlet pressure is increased and the stem is kept in the position by the pawl mechanism.

During standard operation the regulator does not need any manipulation.

To prevent the regulator against closing of the safety device it is needed to have :

- inlet pressure over the stated minimum value ,
- inlet pressure under the stated maximum value ,
- flow under the regulator stated maximum flow rate .

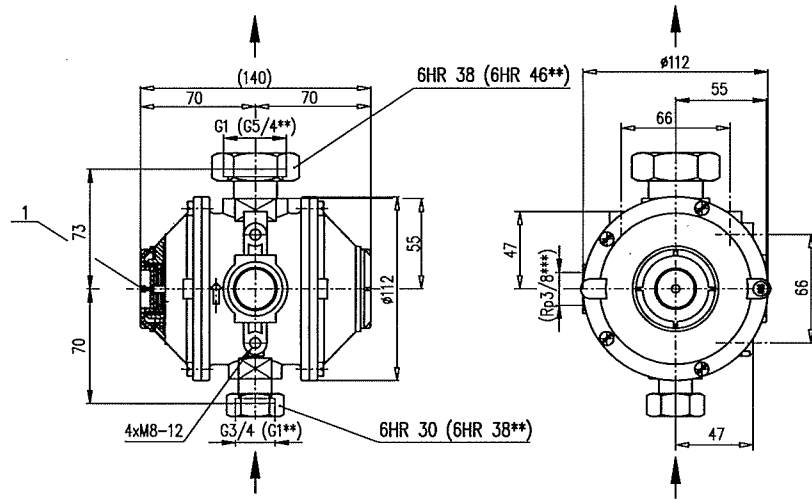

RTP..-M..-P with axial (direct) position of inlet/outlet connection and coupling nuts

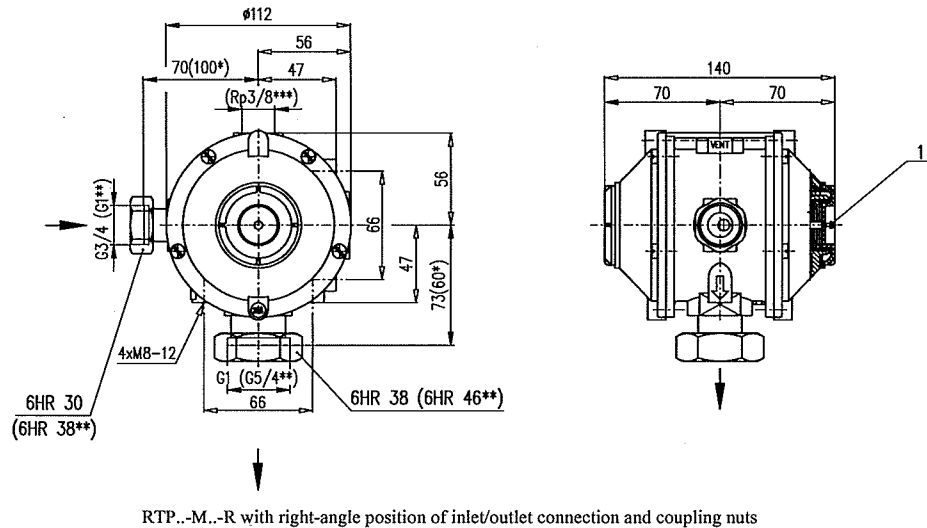

RTP..-M..-R with right-angle position of inlet/outlet connection and coupling nuts

1 – adjuster of safety shut-off device (SSD)
 * - special variant – EU
 ** - connections on special requirement
 *** - dimension of connection thread for connect of relief hole (only for special requirement)
 Note : The part of connect with rotating matrix is the flat packing. A screen is inside of inlet connection.

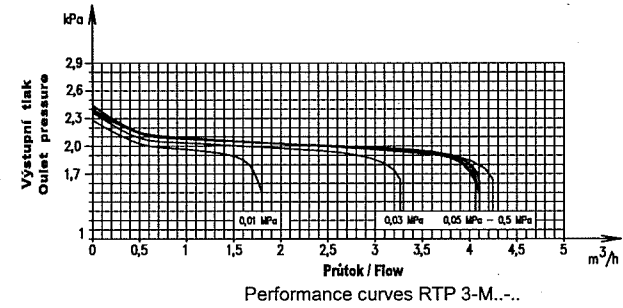

Performance curves RTP 3-M..-

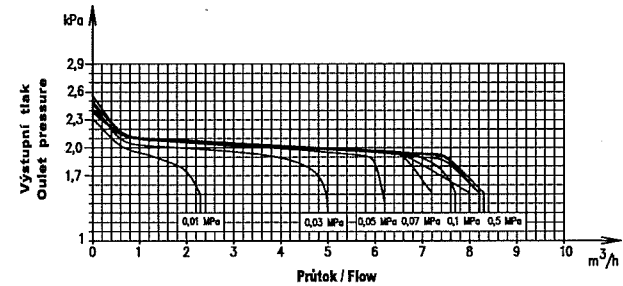

Performance curves RTP 6-M..-

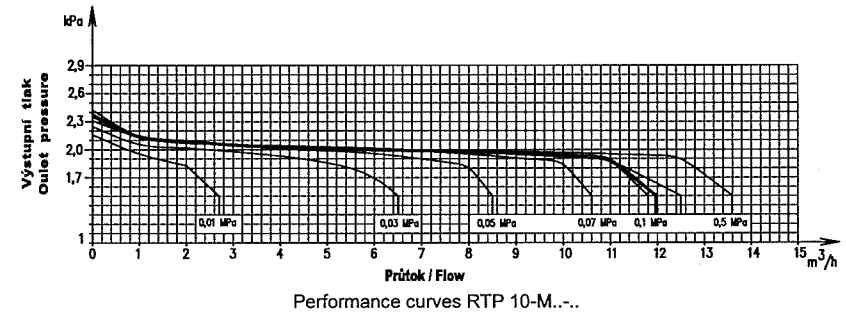

Performance curves RTP 10-M..-

7 Trouble shooting

In case of a RTP malfunction it is needed to contact a nearest service organisation or a gas authority in accordance with law and habits in the country of destination.

After closing of the safety device a qualified person is required to follow these steps:

- close the shut-off valve before the regulator,
- find a reason of the malfunction and repair the regulator (change the screen in the inlet),
- in case of any remarkable damage (breaking of the diaphragm, sealing damages) it is needed to dismantle the regulator and send it to a service shop or to the manufactured plant,
- put the RTP into operation with a procedure described in the part Operation.

The shut-off device (SSD) closes as a result of the following situations:

- remarkable decrease of pressure on the regulator inlet or gas delivery interruption ,
- decrease of pressure on the regulator outlet by over-consumption (piping breaking behind the regulator),
- increase of pressure on the regulator outlet by seat untightness (wear, dirt, ice).