

## 6. Service

### 6.1. Pressure Adjustment

The required value of outlet pressure is to be adjusted with the regulating handle (2). In case of the FR6 type loosen the locking screw (3), on the FR3/8 or FR 1/2 types pull the handle in the direction of device's axis, before manipulating with the handle. Turning the handle following the arrow with the mark "+" the pressure is increasing, following the arrow with the mark "-" the pressure is decreasing. After adjusting of the required pressure which can be checked on the pressure meter screw the locking nut on the FR6 type, on the FR3/8 or FR 1/2 types press the handle down towards the bowl what arranges the arrestment. In case that during the adjustment of the outlet pressure the required value was exceeded, the pressure can be decreased with the handle (the regulating part is equipped with a relief valve) and the pressure is to be adjusted again.

**CAUTION:** The device is designed for operation at the outlet pressure stated on the nameplate. If it is adjusted to the higher value the regulation reliability can be decreased, as well as lifetime of the regulating spring, eventually the spring can be destroyed and this way the regulating function failed.

### 6.2. Drainage of Condensate

Condensate can be drained out of the bowl manually or semi automatically. Manually the condensate is drained with loosening the nut (8), the semi automatic drainage starts at decreasing of the pressure to around zero. If necessary the semi automatic drain allows to drain the condensate with pressing the cap (9) towards the valve corpuscle (10). The manual drainage nut is equipped with a grip locking against dropping out.

## 7. Maintenance

Maintenance and repairs can be performed only by authorised personnel and with no air pressure supply.

Impure filtrating inserts (7) can be replaced by new ones or cleaned with air pressure in the opposite direction of flowing, or having the bowl (6) unscrewed, washing them in petrol or annealing at temperature of 200 °C followed by washing.

The bowl can be cleaned with usual detergents, do not use solvents as acetone, ammonia, lye etc.

If the device is during the maintenance dismantled, the internal parts should be cleaned, sealing checked, functioning parts lubricated, and after mounting the function should be checked.

If the device is stopped working for longer time loosen the regulating nut (4).

## 8. Spare parts

Spare parts are not a part of the delivery. Required spare parts can be ordered stating the type of the device, the name and the position of the part according to the figure, and the number of pieces.

The product was tested by the producer according to the valid technical documentation. Warranty is granted according to the purchase agreement. In case of any fault it is necessary to contact the producer who arranges under-guaranty, after-guaranty repair or sends a spare part.

## 9. Liquidation of Product and Its Package

Parts of the product and its package can be used after dismantling and separation by the material as a source of secondary raw material. The product itself is not a source of environment pollution and do not contain any dangerous waste.

# INSTALLATION, SERVICE AND MAINTENANCE INSTRUCTIONS

## Air cleaner – reduction valve Type: FR6, FR3/8, FR1/2

**1. Application**

The air cleaners – reduction valves (the devices) are combined devices designed to catch liquid and mechanical impurities in pressed air and to keep constant outlet pressure not depending on flow or input pressure changes.

**2. Specifications**

<b>Flowing medium</b> .....	pressed air
<b>Maximum inlet pressure <sup>1)</sup></b>	
FR3/8, FR1/2 .....	1.6 MPa - bowl with cover
FR3/8, FR1/2 .....	1 MPa - bowl without cover
FR6 .....	1.2 MPa
<b>Outlet pressure <sup>1)</sup></b> .....	0.05 MPa - 1 MPa
.....	0.05 MPa – 0.63 MPa
.....	0.02 MPa – 0.4 MPa
<b>Useful capacity of bowl</b>	
FR6 .....	41 cm <sup>3</sup>
FR3/8, FR1/2 .....	85 cm <sup>3</sup>
<b>Connecting thread</b>	
FR6 .....	G1/4
FR3/8 .....	G3/8
FR1/2 .....	G1/2
<b>Thread for pressure meter</b> .....	M12 x 1,5
<b>Filtration ability</b> .....	55 µm, 25 µm, 10 µm
<b>Ambient and flowing medium temperature</b> .....	from + 5 °C up to + 60 °C

<sup>1)</sup> According to the data placed on the nameplate.

**3. Description and Functioning**

The device functions on the principle of centrifugal separation of liquid impurities from pressed air, which is then filtrated from mechanical impurities flowing through the porous filtration insert.

The regulating part allows adjusting the required outlet pressure and its maintaining regardless of flow rate and inlet pressure changes.

**4. Mounting**

Devices are mounted onto or into the piping in vertical position – the bowl placed down. For fixing use connecting parts according to the catalogue or holes and threads of the body. The air flow direction has to be in accordance with the arrow placed on the body. If the device is delivered without as pressure meter one of the two end-seals can be unscrewed with a screw-wrench No. 6 and a pressure meter can be screwed into.

Inlet and outlet can be connected with couplings for plastic hoses or metal threaded tubes.

**5. Putting into Operation**

Loosen the regulating spring using the regulating handle, and check the condensate drain plug (described in the next chapter) before starting of pressure air supply.

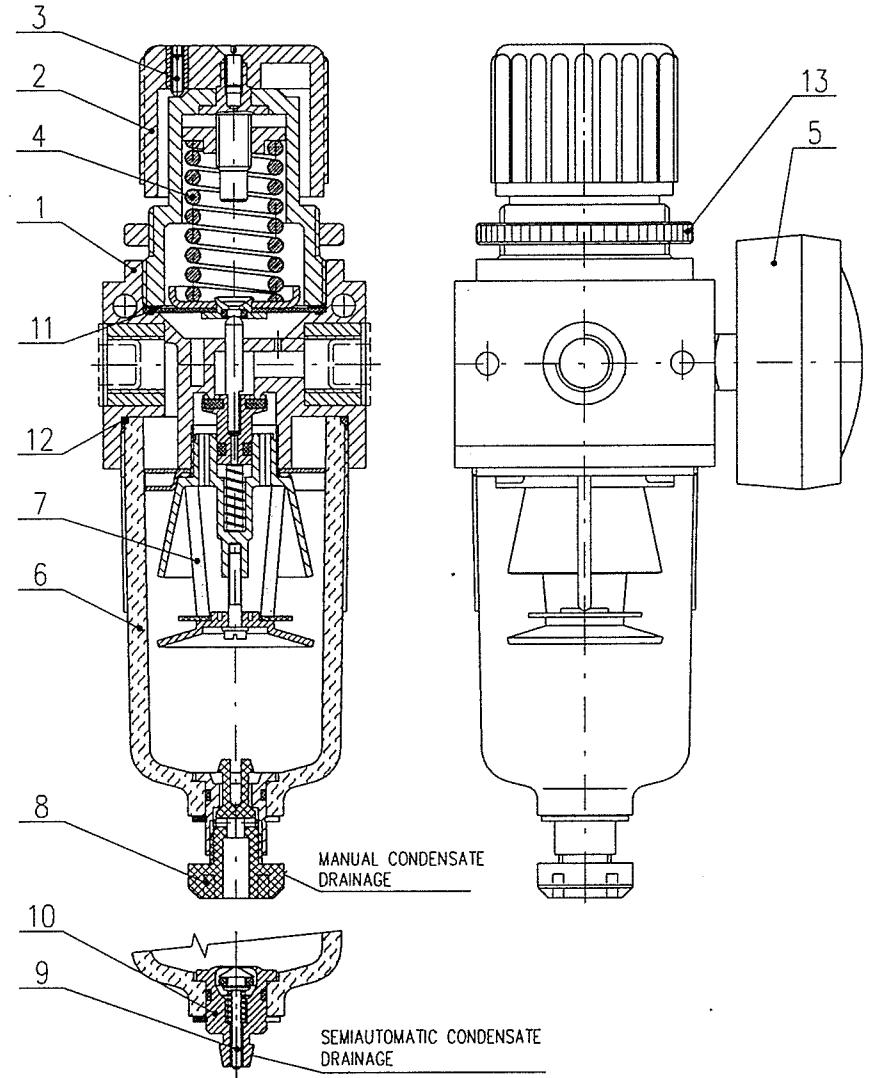

**Legend:**

- |        |                |         |                     |
|--------|----------------|---------|---------------------|
| 1..... | body           | 7.....  | filtrating insert   |
| 2..... | handle         | 8.....  | drain nut           |
| 3..... | locking screw  | 9.....  | cap                 |
| 4..... | spring         | 10..... | drain tap corpuscle |
| 5..... | pressure meter | 11..... | membrane            |
| 6..... | bowl           | 12..... | sealing ring        |
|        |                | 13..... | rotating nut        |