



INSTALLATION, SERVICE AND MAINTENANCE INSTRUCTION

Double 3-way valves solenoid operated

***Type: 3VEE20DF
3VEE25DF
3VEE20DFA
3VEE25DFA***

REGADA, s. r. o., Strojnícka 7
080 01 Prešov, Slovenská republika
Tel.: +421-51-7480 465, 7480 464
Fax: +421-51-7480 466
E-mail: regada@regada.sk
www.regada.sk

REGADA

75 0336 03

Application

3/2 valves of solenoid pilot-operated type are two-way valves with two parallel branches having a single input, output and exhaust.

They are used for dual mode control of pneumatic performance elements such as clutches and brakes of presses or other forming machines

Description and function

Should one of the valve branches fail, i.e. should only one branch be set, compressed air is supplied through an open input seat and released through the second branch to the atmosphere. The reached residual pressure on output „ 2 „, is low (less than 10% of input pressure), and is insufficient for press clutch engagement.

Valves of 3VEE20DFA and 3VEE25DFA type are equipped with a block of function electric checking – there are connecting rods (12) of the both branches coming out in the lower part and their position is monitored by two contact switches (30). This makes both, static and dynamic valve function checking, possible.

Valves of 3VEE20DF and 3VEE25DF type do not have a block of function electric checking.

Valve technical data according to TP 75 0337/02

Parameter		Type			
		3VEE20DF	3VEE20DFA	3VEE25DF	3VEE25DFA
Diameter DN [mm]		20		25	
Operating pressure [MPa]		0,2 to 0,8			
Connecting thread	Inlet „ 1 „	G1/2		G1	
	Outlet „ 2 „	G3/4		G1	
	Exhaust „ 3 „	G1 1/4		G1 1/4	
Weight [kg]		3,2	3,8	3,1	3,7
Flow space [mm ³]					
direction 1-2		80		80	
direction 2-3		300		500	
Max switching speed [min ⁻¹]		180			
Ambient temperature [°C]		-5 to +50			
Fluid temperature [°C]		+2 to +60			
Flowing fluid requirements		Conditioned compressed air			
Solenoid electrical data	Coil voltage	230V, 110V, 48V, 42V, 24V – 50Hz, 60Hz 24V DC			
	Power coil	15VA 10W			
	Enclosure	IP 65 – coil insulation class F			
	Duty	permanent			
Electrical data of the block electric function checking	Switches	Limit switches with forced contacts switching			
	Switches loading	max. 10A			
	Enclosure	IP 54			

Applied materials

Body..... aluminum alloy
Coil..... PA6 fully encapsulated
Electric switches cover modified PP

Installation

The valves are vertically mounted on the device with coils placed above the valve. When mounting the valve on the pipeline, control solenoids cannot be used as a counter power. The valves are designed for the use in closed rooms (objects) with no effect of atmospheric precipitations, direct sunlight or moisture condensation. Based on operating conditions and quality of compressed air in the distribution system, it is recommended to place an air treatment unit with filtering capacity of at least 55 µm in front of the valve. In order to attach the valve to the equipment, two fixing holes of $\varnothing 8.4$ can be used. The valve has to be fixed as close to the driving part (clutch, brake) as possible. There cannot be any other building element mounted between the valve and the clutch with the brake. The connecting dimensions of elements in front of the valve, air treatment unit, must, at least, correspond with the dimensions of the valve entry connection.

In order to reduce the noise level in the area around the machine, a silencer of dimensions corresponding, at least, with the dimensions of the exhaust threaded connection is mounted on the exhaust of the valve. The silencer has to discharge air directly in the atmosphere and cannot get clogged if to avoid any reduction in air exhaust rate from the clutch and thus ensure the safe operation of the press.

When assembling the valves on the machines, the requirements arising from "EN 692 – Machine tools. Mechanical presses. Safety" and "EN ISO 13849-1 – Safety of machinery. Safety-related parts of control systems. Part 1: General principles for design" have to be met.

Diagram of recommended valve connection

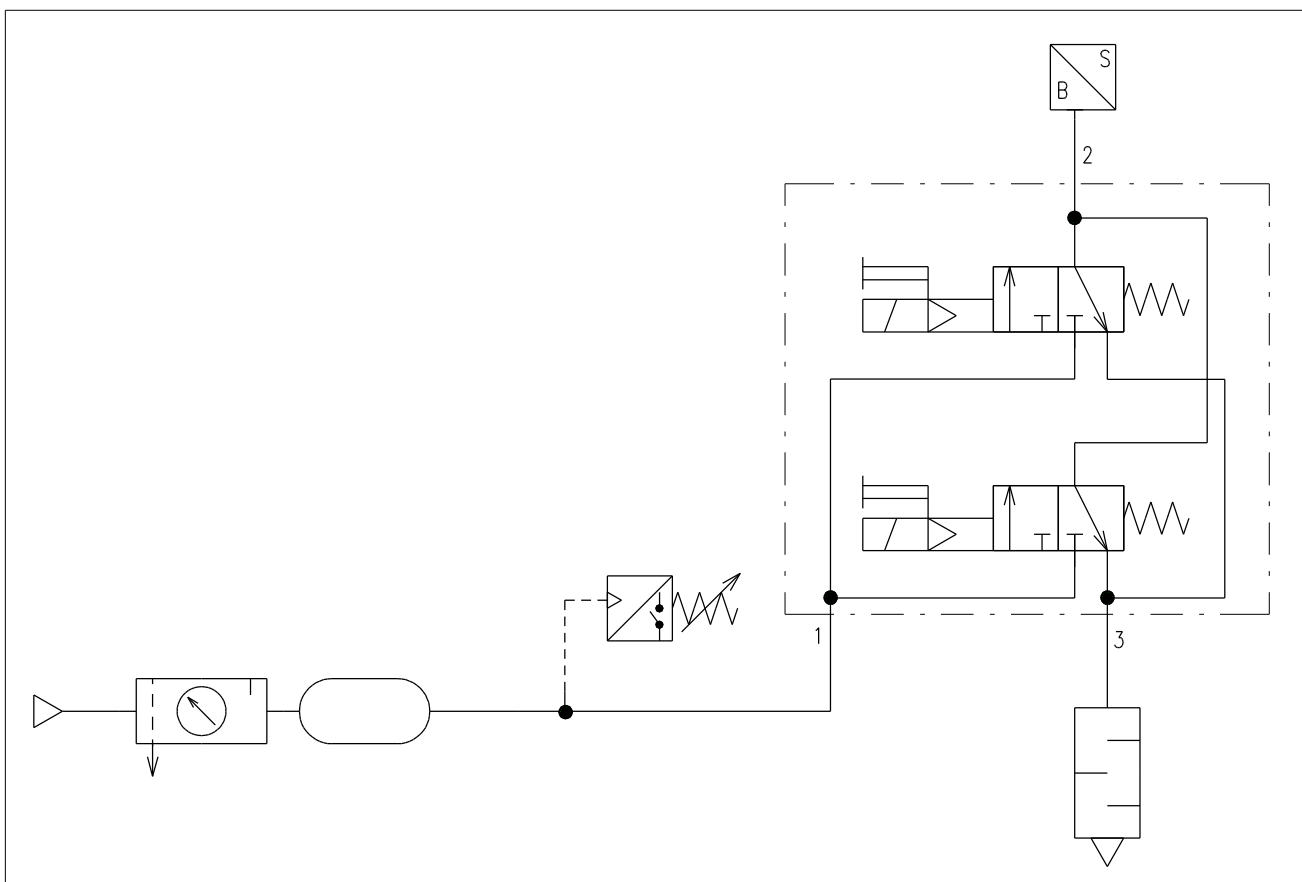

Electrical connection

Valves equipped with a block of function electric checking will be wired by the user based on requirements arising from standards for relevant machine control.

Connect the coil in accordance with National electrical Engineering Standards. Before coil connection check electric data on coil and mains voltage. Voltage is connected to terminals marked on terminal board. Protective conductor must be safely connected to protective terminal, which is marked on the terminal board. The electrical cable must be effectively sealed in a plug. Electric connector plug provides protection for coil IP 65.

Coil is mounted to valve rotated in 360°. The plug can be positioned on the coil by 4 x 90°. Voltage can be connected to the coil only when assembled on the valve, the coil for alternating power can be damaged during connection, if it is not slipped on the core guide.

Attention: Coil at continuous operation without media flow - DANGER OF BURNS BY TOUCH BY UNPROTECTED BODY PARTS!!!!!!! The coil is designed for continuous operation and therefore mentioned warming of coil does not restrict its permanent use. In case of excessive heating the thermal injury of coil winding

would be accompanied by smoke and smell of burning coil insulation and in that case, the coil must be immediately disconnected from electrical power supply!!!!
 The valve can only be wired by a certified professional.

Diagram of valves 3VEE20DFA, 3VEE25DFA wiring with block of electric function checking

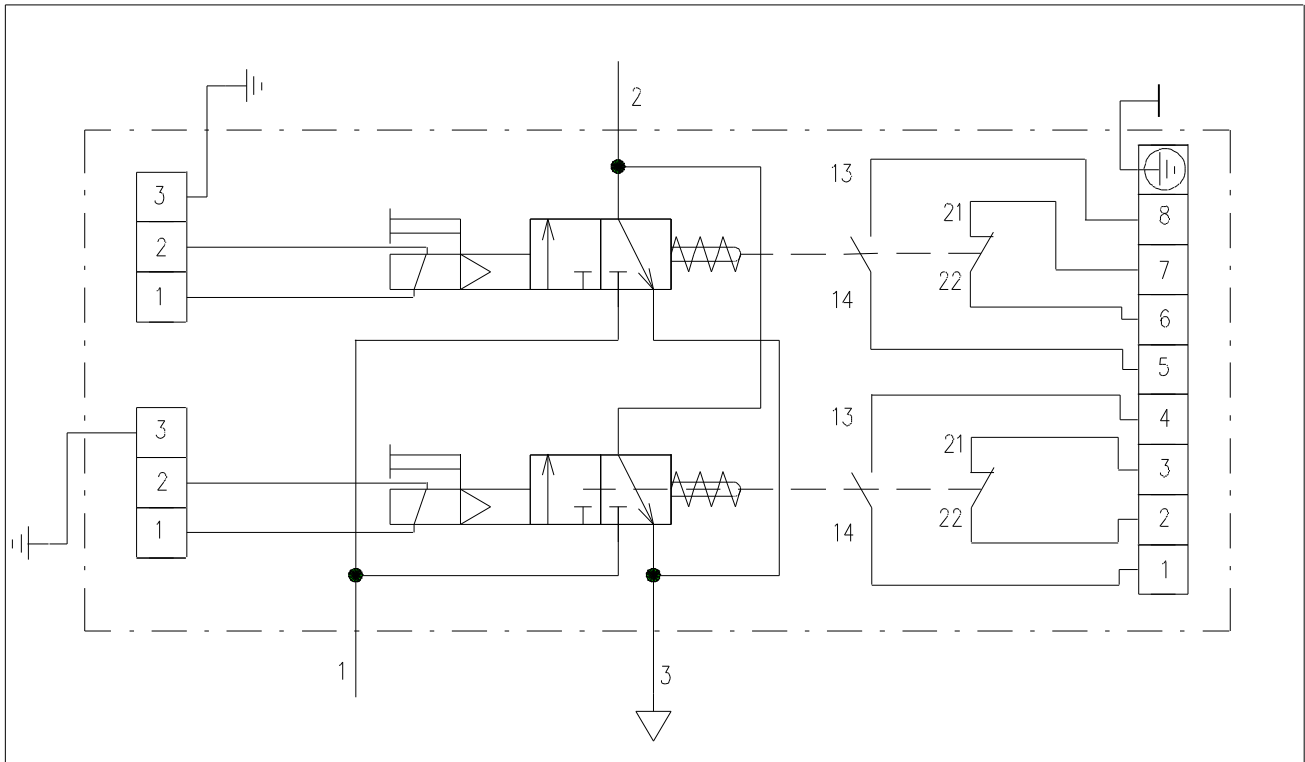

Servis

Operating conditions have to be in accordance with the specified technical data of the valve. Before putting in operation, it is necessary to check the correctness of wiring and the value of voltage with reference to the data stated on the coil. Moreover, the protective circuit of the 3VEE20DFA and 3VEE25DFA valve type has to be checked. It is recommended to test the functioning of the solenoid. When connecting to the power supply, it should be possible to hear the solenoid core click. While connecting the solenoid, its coil for alternating current can get damaged if not put on the core guide. Once in operation, valves do not require any special care.

The valve can be manually overridden if in emergency e.g. when aligning the machine. The manual control cam is accessible upon yellow cover removal. The manual control is placed in the flange under the control solenoids. Solenoid cores can be manually reset to position “I” at the same time using a screw driver (the groove of the cam turned to position I – see the detail of manual control).

The level of the set-up compressed air pressure necessary for press clutch activation has to be 10% higher than supply pressure in order to block clutch activation if the valve fails. Otherwise the press control might not be safe.

Maintenance

Maintenance and repairs can only be carried out once the machine is no longer under pressure. Maintenance is carried out according to the instructions of manufacturer of machines where valves are mounted on and in accordance with the requirements of corresponding standard for equipments. It is recommended make testing for safety function of valves in machine at least yearly.

If the device needs to be dismantled as a part of maintenance, it is necessary to clean internal parts, check seal conditions, lubricate moving parts of the device at least once a year based on the character of its operation. Once back in position, the device has to be checked for leakage and faulty functioning applying the procedure described in the Operation section. Only tools recommended by the manufacturer can be used for disassembly..

It is necessary to check regularly conditions of silencer within the maintenance of the press as required by Art. 5.2.5.2 EN 692.

It is also necessary to pay attention to correct functioning and maintenance of air treatment elements on the valve input and to observe their manufacturer’s operating instructions.

The staff assembling, operating and maintaining the machinery have to meet the certification requirements as per relevant legal regulations.

Valve cross-section 3VEE20DF, 3VEE25DF

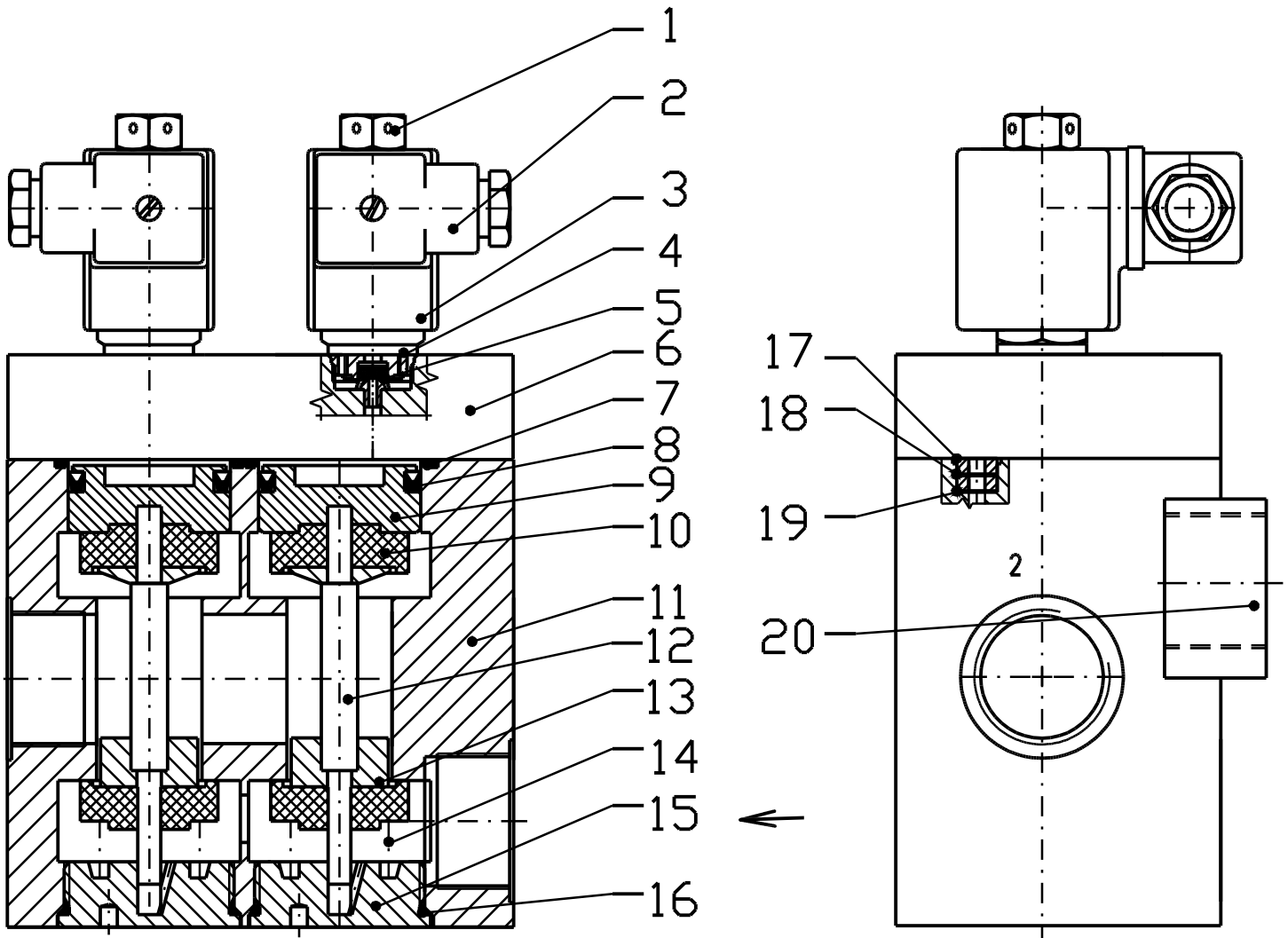

Legend

- | | |
|-------------------|---------------------|
| 1 – Nut | 11 – Body |
| 2 – Plug | 12 – Rod |
| 3 – Coil | 13 – Insert |
| 4 – Core guide | 14 – Spring |
| 5 – Core | 15 – Nut |
| 6 – Flange | 16 – Sealing ring |
| 7 – Sealing ring | 17 – Sealing ring |
| 8 – Sleeve | 18 – Filter |
| 9 – Piston | 19 – Sealing ring |
| 10 – Seat sealing | 20 – Exhaust flange |

Valve graphics symbol 3VEE20DF, 3VEE25DF

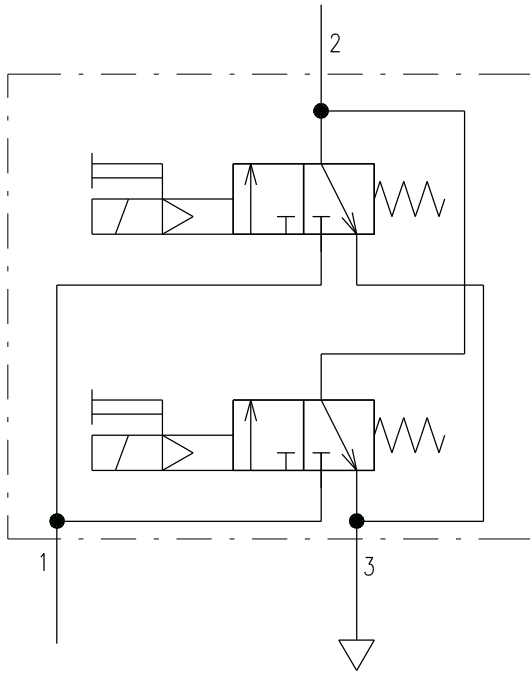

Manual control detail

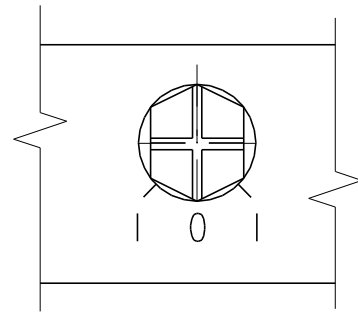

Valve dimensions 3VEE20DF, 3VEE25DF

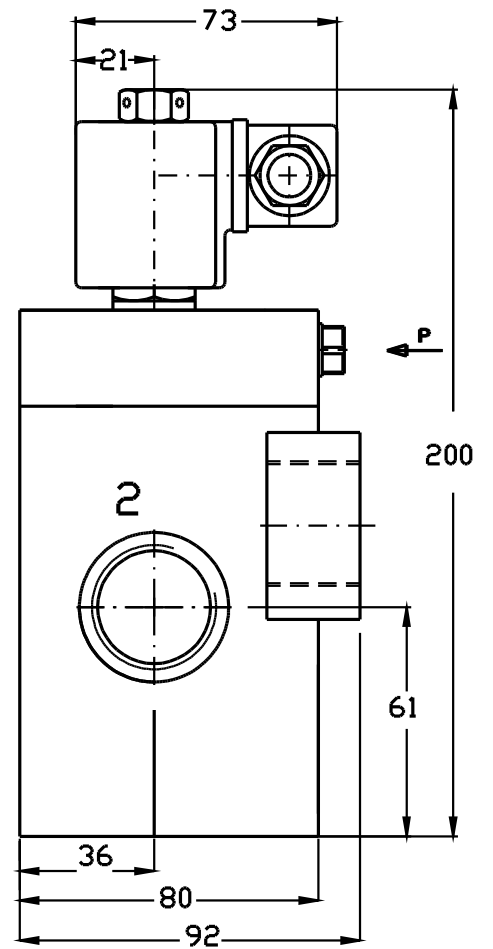
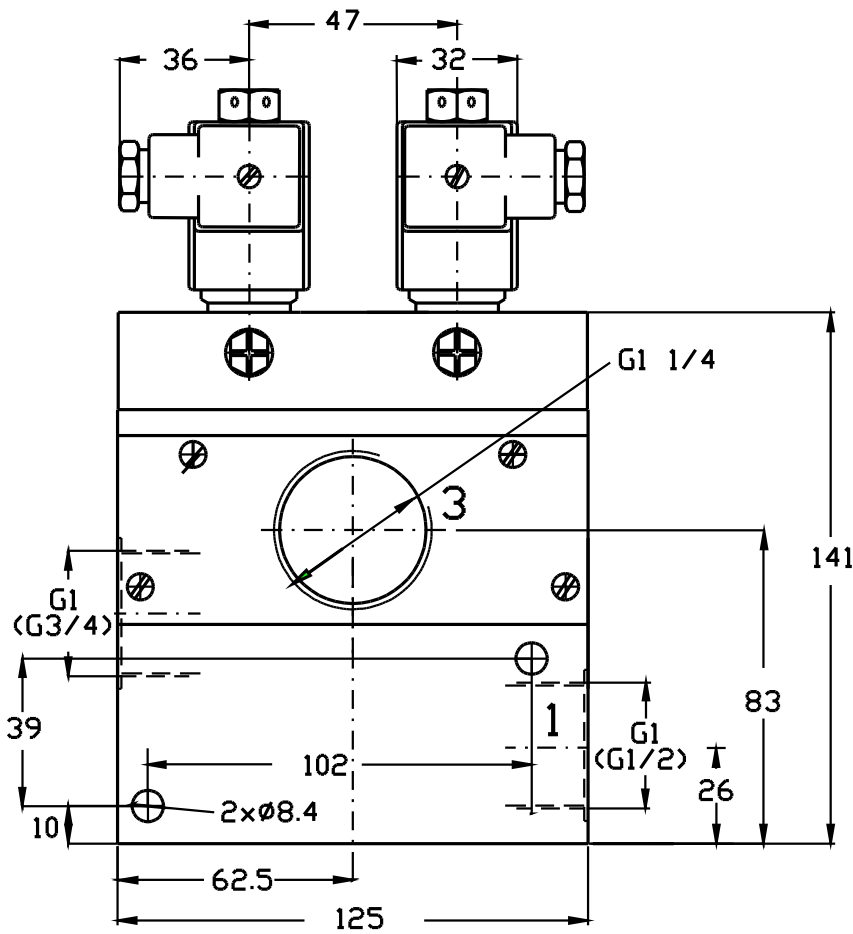

Valve cross-section 3VEE20DFA, 3VEE25DFA

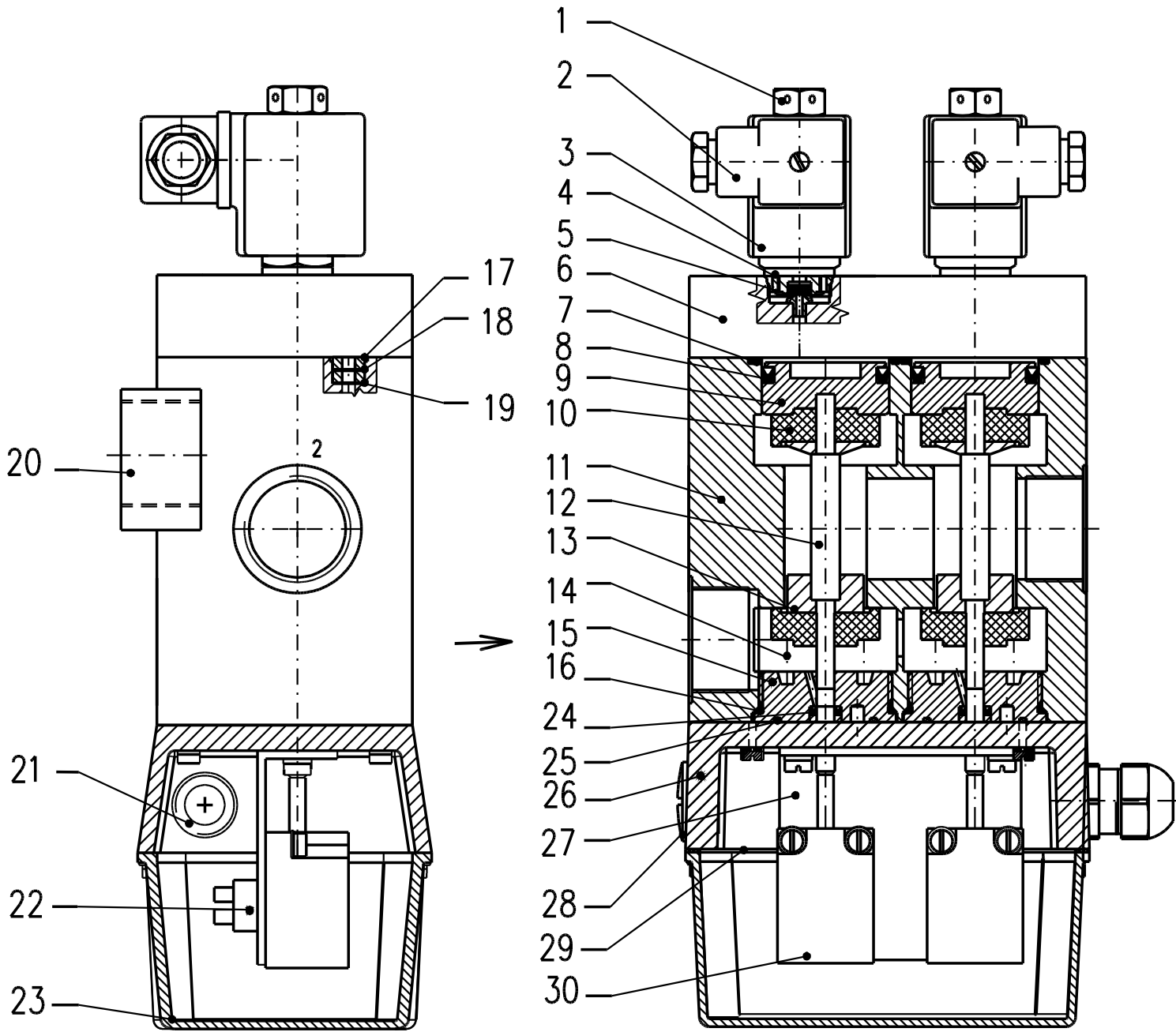

Legend

- | | | |
|---------------------------|-------------------------|-------------------------|
| 1 – Nut | 11 – Body | 21 – Bushing |
| 2 – Plug | 12 – Rod | 22 – Terminal board |
| 3 – Coil | 13 – Insert | 23 – Cover |
| 4 – Core guide | 14 – Spring | 24 – Sleeve (SND) |
| 5 – Core - sealings (SND) | 15 – Nut | 25 – Sealing ring (SND) |
| 6 – Flange | 16 – Sealing ring (SND) | 26 – Intercover |
| 7 – Sealing ring (SND) | 17 – Sealing ring (SND) | 27 – Bearer |
| 8 – Slee (SND) | 18 – Filter (SND) | 28 – Tap |
| 9 – Piston | 19 – Sealing ring (SND) | 29 – Sealings (SND) |
| 10 – Seat sealing (SND) | 20 – Exhaust flange | 30 – Limit switch |

Note : Items marked with the abbreviation "SND" are part of sets of spare parts

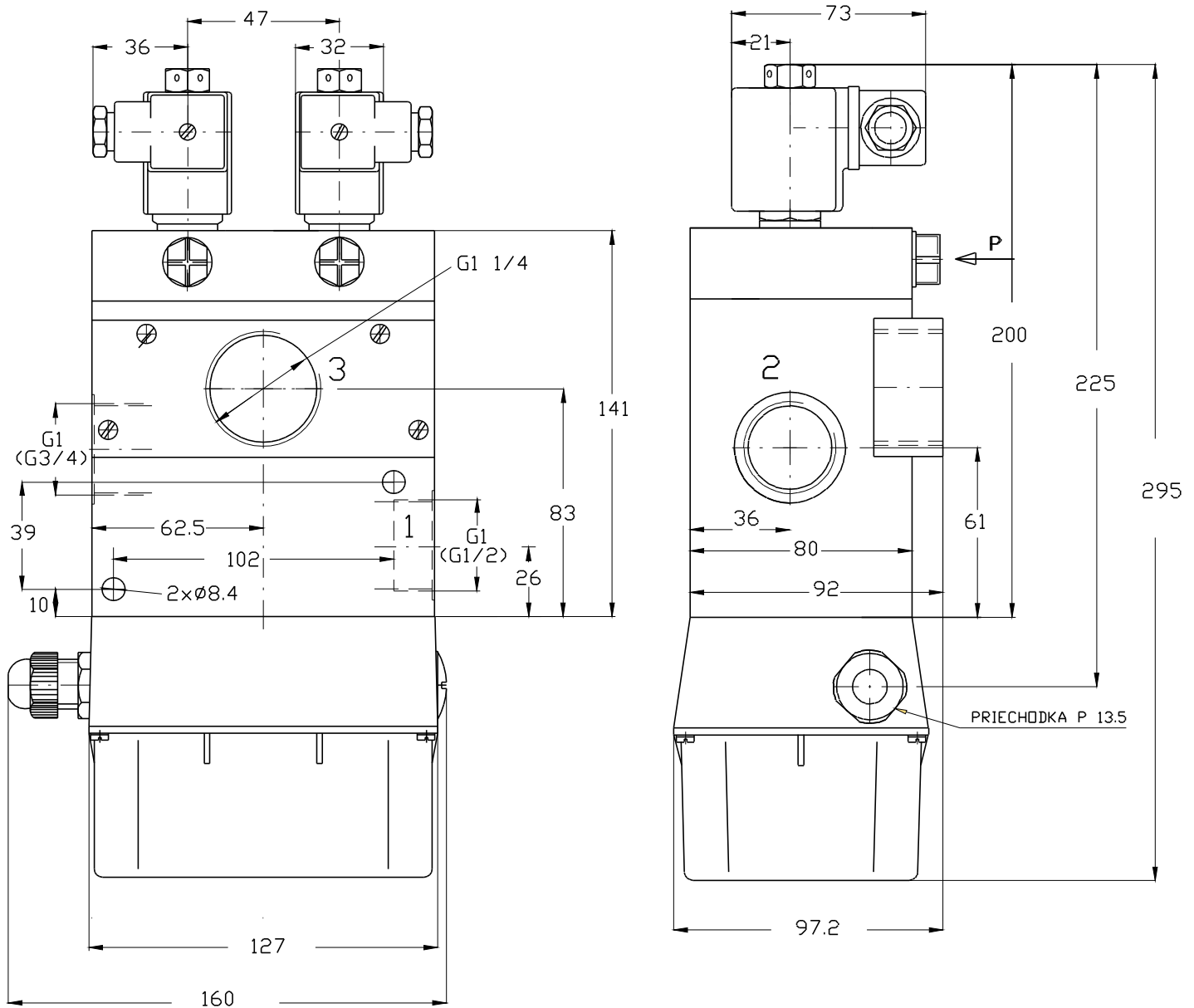
Valve dimensions 3VEE20DFA, 3VEE25DFA**Guarantee and Service**

The manufacturer is responsible for valves properties for a minimum of 12 months from delivery of goods if the purchase contract has not been established by another warranty period. The manufacturer is responsible for ensuring that this product has and, during the prescribed period, will have properties established by technical standards, conditions, regulations and properties as agreed in the purchase contract.

Warranty does not cover defects caused by improper or forcible manipulation with the product.

The manufacturer is not responsible for the worsening of the product or damage caused by failure of buyer who doesn't comply with these instructions, or someone else's by bad storage, incorrect connection of the product or damage caused by disaster natural.

Warranty or Post-warranty services are carried by manufacturer or its authorized agencies that are qualified to do so by the manufacturer.

Product liquidation

Components and pack can be used as source of secondary raw material.

Product is not source of environmental pollution and doesn't include danger scrap.