



INSTALLATION, SERVICE AND MAINTENANCE INSTRUCTIONS



***Electric part-turn actuators Rematic
with the DMS 3 electronic control
SPR 1PA, SPR 2PA, SPR 2.3PA, SPR 2.4PA***

TEST CERTIFICATE

| | |
|---|-------------------------------|
| ELECTRIC PART-TURN ACTUATOR SPR 1PA, SPR 2PA, SPR 2.3 PA, SPR 2.4PA | |
| Type number | Power supply V Hz |
| Serial number | Max. load torque Nm |
| Production year | Switching-off torque Nm |
| Wiring diagram..... | Operating time s/90° |
| | Operating angle ° |
| | Input operation signal |
| Warranty period months | Output signal |
| Serial number of electric motor | |
| Serial number of control unit | |
| Tests made by | Packed by |
| Date | Signature and stamp |

COMPLETENESS CERTIFICATE

| | |
|------------------------------|--------------------------|
| Used valve | |
| Assembled by: Firm | |
| Name..... | |
| Warranty period months | |
| Date | Signature and stamp..... |

INSTALLATION CERTIFICATE

| | |
|-----------------------------|--------------------------|
| Location | |
| Installed by: Firm | |
| Name | |
| Warranty period..... months | |
| Date | Signature and stamp..... |

Please read these instructions carefully before mounting and operating the actuator!

Preventive and safety-measures applied on the actuator can not offer required safety level till the actuator and its safety systems are not applied by required and described way and if installation and maintenance is not applied according to applicable instructions and rules!

Contents

| | | |
|------|---|----|
| 1. | General data | 2 |
| 1.1 | Purpose and applications..... | 2 |
| 1.2 | Safety instructions..... | 2 |
| 1.3 | Warning for safety use | 3 |
| 1.4 | Data specified on electric actuator..... | 3 |
| 1.5 | Warranty conditions | 3 |
| 1.6 | Under-guarantee and after-guarantee service..... | 3 |
| 1.7 | Operation conditions | 4 |
| 1.8 | Description and function | 6 |
| 1.9 | Basic specifications..... | 9 |
| 1.10 | Packing, transport, storing and unpacking..... | 19 |
| 1.11 | Assessment of the product and packaging and removal of contamination | 19 |
| 2. | Installation and dismantling of actuator | 20 |
| 2.1 | Installation | 20 |
| 2.2 | Dismantling | 21 |
| 3. | Adjusting of actuator | 22 |
| 3.1 | EA control set-up options (regulating)..... | 25 |
| 3.2 | Procedure for setting individual parameters and the register of errors and warnings..... | 27 |
| 3.3 | Putting an EA into operation when the EA is set up and connected with the armature already in the production plant (starting the calibration)..... | 30 |
| 3.4 | Putting an EA into operation when the parameter setting done by the producer suit to your needs | 30 |
| 3.5 | Putting an EA into operation when it is necessary to do a change to the angle (setting new end positions), and the other parameter setting done by the producer suits to your needs | 30 |
| 3.6 | Setting other parameters | 31 |
| 3.7 | Error messages from the control unit..... | 31 |
| 3.8 | Resetting of operation angle and setting of stop end screws | 32 |
| 4. | Service, maintenance and troubleshooting..... | 33 |
| 4.1 | Service | 33 |
| 4.2 | Maintenance - extent and periodicity | 34 |
| 4.3 | Troubleshooting | 35 |
| 5. | Accessories and spare parts | 37 |
| 5.1 | Accessories..... | 37 |
| 5.2 | Spare part list..... | 37 |
| 6. | Enclosures | 38 |
| 6.1 | Wiring diagrams EA SPR PA – for single - phase supply..... | 38 |
| 6.2 | Wiring diagrams EA SPR 1PA – for three - phase supply..... | 39 |
| 6.3 | Wiring diagrams EA SPR 2PA, SPR 2.3PA, SPR 2.4PA – for three - phase supply | 40 |
| 6.4 | Wiring diagrams EA SPR PA – for three - phase supply without reverse unit..... | 41 |
| 6.5 | Wiring diagrams ES SPR PA – for three phase supply with-contactless switching | 42 |
| 6.6 | Wiring diagrams EA SPR 2PA, SPR 2.3PA, SPR 2.4PA with interface Modbus/Profibus - three - phase supply..... | 44 |
| 6.7 | Dimensional drawings..... | 47 |
| 6.8 | Guarantee service check report..... | 55 |
| 6.9 | Post guarantee service check report | 56 |
| 6.10 | Commercial representation..... | 57 |

The Installation, Service and Maintenance Instructions are drawn up according to requirements of EC Executive Nr. 2006/42/EC "Uniform requirements for machines and devices from the point of view of safety and health care", to save life and health of users and to avoid material damages and exposure environment to danger.

1. General data

1.1 Purpose and applications

Electric part-turn actuators **Rematic** (hereinafter referred as EA only) with the DMS 3 electronic control of the **SPR 1PA, SPR 2PA, SPR 2.3PA, SPR 2.4PA** type (hereinafter referred as **SPR PA** only) are set up by the program to be controlled on the 24 V DC voltage level; are set up by the program to be controlled by **analogue input signal**, potentially controlled through a interface with Modbus communication protocol.

Electric part-turn actuators **SPR PA** types are high-powered electric-mechanical products designed for direct installations onto controlled devices (regulating bodies - valves, etc.). EA of SPR PA types are provided for remote control of closing bodies, or for automotive control of regulating bodies in both directions of their movement. They can be equipped with means of measuring and control of technological processes where an unified analogue direct current resp. voltage signal is an information bearer on their input and/or output (not valid for EA with Modbus protocol). They can be used in heating, energy, gas, air-conditioning and other technological systems, which they are suitable for, regarding their features. They are connected with controlled devices with a flange according to ISO 5211 and a coupling or using a stand and a coupling/a lever.



It is forbidden to use EA as a lifting mechanism!

1.2 Safety instructions

1.2.1 Characteristics of the Product Regarding Its Exposure Rate



EA of SPR PA types are reserved technical devices with higher rate of danger, with possibility of installation in areas specially danger regarding casualties caused by electric current.

Electric actuators are according to directive LVD 2014/35/EU and standard EN 61010-1 within valid edition assigned for installation category II (overvoltage category).

1.2.2 Product influence to environment

Electromagnetic compatibility (EMC): the product complies with the requirements of the Directive 2014/30/EU of the European Parliament and of the Council on the approximation of the laws the Member States relating to the electromagnetic compatibility and with the requirements of standards as well EN 55014-1(CISPR 14-1), EN 55014-2 (CISPR 14-2), EN (IEC) 61000-3-2 and EN (IEC) 61000-3-3 within valid edition..

Vibrations caused by the product: product influence is negligible

Noise produced by the product: The maximum allowable noise level (A) of the product measured in a place of operation is 78 dB (A).

1.2.3 Requirements for professional qualification of people performing installation, service and maintenance



*Electric connection can be performed only by an acquainted person, i.e. an **electrical engineer** with professional education of electrical engineering at an apprentice school or a technical school (secondary, complete secondary or university education) and whose qualification was verified by an educational facility authorised to verify professional qualification.*

1.2.4 Instructions for staff training



Service can be performed only by workers professionally qualified and trained by the producer or contracted service centre.

1.3 Warning for safety use

Product protection

There must be included suitable protective device into the supply power (circuit breaker or fuse) which serves at the same time as main switch.

EA SPR PA with single - phase has own short-circuit protection electronic circuits and space heater. There must be included suitable protective device into the supply power of three - phase motor (circuit breaker or fuse) which serves at the same time as main switch.

Type of equipment from a connection point of view: The equipment is designed for permanent connection.

1.4 Data specified on electric actuator

Nameplate:

Warning plate:

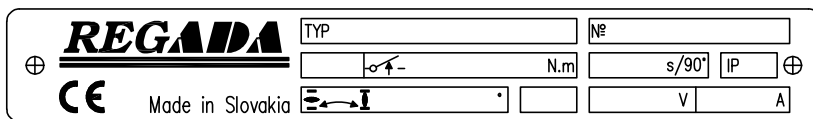

Name plate contains the basic data concerning identification, performance and electricity: indication of producer, type, serial number, max. load torque and switching-off torque, operating time, protection code, operating angle, supply voltage and current.

Graphic symbols on electric actuator

The graphic symbols used on electric actuator substitute the text messages. Some of them are in accordance with EN ISO 7010, ISO 7000 and IEC 60417 [within valid edition](#).



Dangerous voltage

(EN ISO 7010-W012)



Stroke of the electric part-turn actuator



Switching-off torque



Manual control

(0096 ISO 7000)



Protection terminal

(5019 IEC 60417)

1.5 Warranty conditions

The supplier is responsible for completeness of the delivery and guarantees these specifications of the product which are stated in Technical conditions (TP) or specifications agreed in the Contract.

The supplier is not responsible for any deterioration of parameters caused by the customer during storage, unauthorised installation or improper operation.

1.6 Under-guarantee and after-guarantee service

Under-guarantee service is performed by the service department of the production plant, or by a contracted service centre according to a written claim.

In case of occurring of any fault please let us know it and state:

- type code
- serial number
- ambient parameters (temperature, humidity...)
- duty cycle including frequency of switching
- type of switching-off (position or torque)
- set switching-off torque
- type of fault - description of claimed fault
- it is recommended to place also Installation certificate.

It is recommended to have **after-guarantee service** performed by the service department of the production plant, or by a contracted service centre. Serviceman makes the record about service mission after warranty actions and sends it to the production company.

1.6.1 Lifetime of actuators

The lifetime of an electric actuator (EA) is at least 6 years.

EA used for closing mode (closing valves) comply with the requirements for at least **15,000 working cycles** (cycle C – O – C: for part-turn EA)

EA used for regulating/modulating operation (control valves) comply with the below stated numbers of **operating hours** at the total number of 1 million start-ups:

| Switching frequency | | | | |
|---|--------------------------|------------------------|------------------------|------------------------|
| max. 1,200 [h ⁻¹] | 1,000 [h ⁻¹] | 500 [h ⁻¹] | 250 [h ⁻¹] | 125 [h ⁻¹] |
| Minimal lifetime expectancy – number of operating hours | | | | |
| 850 | 1,000 | 2,000 | 4,000 | 8,000 |

Time of **net operation** is min. 200 hours, max. 2,000 hours.

Lifetime at operating hours depends on loading and switching frequency.

Note : High switching frequency does not ensure better regulation. Setting of regulation parameters should be therefore made with the inevitably necessary switching frequency needed for the process in question.

1.7 Operation conditions

1.7.1 Product location and operation position

- The assembly and operation of electric actuators in standard make can be on covered places of industrial objects without the regulation of temperature, humidity and with protection against direct exposure of climate influence (e.g. direct sun shine).
- Electric actuators must be placed with access to the manual control wheel, to the cover of control box, to control box, to cable glands, resp. to local control.
- Installation and operation of actuators is possible in either position. Common position is the one with vertical position of exit part axis and control box above. Avoid to arrange the electric actuator under the armature if possible.

Warning:



Actuator installed on the open place must be protected against a direct climate effects by shelter, mainly from sunshine.

In applications placed in an ambient of a relative moisture above 80%, in external ambient under shed, it is necessary to change the preset thermostat temperature +25°C to +70°C by a PC and program to prevent switching off the heating resistor.

1.7.2 Operation Environment

According to valid standard IEC 60 721-2-1, there are delivered these versions of electric actuators:

- 1) Version „**temperate**“ for climate temperate
- 2) Version „**cold**“ - for climate cold
- 3) Version „**tropical**“ for climate tropical and dry
- 4) Version „**marine**“ for climate marine.

In accordance with IEC 60 364-1, IEC 60 364-5-51 and IEC 60 364-5-55 within valid edition the EA have to resist external effects and operate reliably:

In the conditions of the following types of environment:

- warm mild to very hot dry with temperature in range -25°C to +55°C **AA 7***
- cold, warm mild to hot dry with temperatures -50°C to 40°C..... **AA 8***

in industrial environment: at temperatures stated above

- with relative humidity 10 to 100 %, including the condensation of up to 0,029 kg water content per 1 kg of dry air at 27 °C, with temperatures from -25°C up to +55°C **AB 7***
- with relative humidity of 15÷100%, including the condensation of up to 0,036 kg water content per 1 kg of dry air at 33 °C direct exposed to a possible rainfall, with temperatures from -50°C up to +40°C **AB 8***
- with height above sea level 2 000 m, with barometric pressure range 86 to 108 kPa **AC 1***

- with spraying or jet water from all directions–(protection enclosure IP x5)AD 5*
- with shallow dive – (product in protection IP x 7)AD 7*
- with strong dustiness – with a possibility of influences of inflammable, non-conducted and non-explosive dust; the middle layer of dust; the dust drop more than 350 but not more than 1000 mg/m² per day (products with protection enclosure of IP 6x)AE 6*
- with atmospheric occurrence of corrosive and pollution media (with high degree of atmosphere corrosive aggressiveness); important presence of corrosive pollutionAF 2*
- with permanent exposure of big amount of corroding or contaminated chemicals and salt fog in execution for sea environment , for sewage water disposal plant and some chemical plantAF 4*
- with a possibility of influences of mechanical stress:
 - medium sinusoid vibrations with frequency in range 10 up to 150 Hz, with shift amplitude of 0,15 mm for $f < f_p$ and acceleration amplitude 19,6 m/s² for $f > f_p$; (transition frequency f_p is from 57 up to 62 Hz)AH 2*
 - medium impacts, shocks and vibrationsAG 2*
- with serious danger of plants and moulds growingAK 2*
- with serious danger of animals occurrence (insects, birds, small animals)AL 2*
- with detrimental influence of radiation:
 - of stray current with intensity of magnetic field (direct and alternating of power supply frequency) to 400 A.m⁻¹AM 2-2*
 - of sun radiation with intensity > 500 a ≤ 700 W/m²AN 2*
- with effects of medium seismic activity with acceleration > 300 Gal ≤ 600 GalAP 3*
- with indirect danger of storm activityAQ 2*
- with fast moving of air and strong windsAR 3 , AS 3*
- with persons frequent touching earth potential (persons often touch conductive parts or they stand on the conductive basement)BC 3*
- without any danger media with objectBE 1*

* Marking in accordance with IEC 60364-1, IEC 60 364-5-51 and IEC 60 364-5-55 within valid edition

1.7.3 Power supply and duty cycle

Power supply:

electric motor 110/120 V AC, 220/230/240 V AC, 3x400/3x380 V AC resp. 24 V CA $\pm 10\%$ (other - after agreement with manufacturer)

control binary inputs 24 V DC $\pm 10\%$

input control signal 0/4/12 to 20 mA, 4 to 12 mA resp. 20 to 0/4/12 mA, 12 to 4 mA, or 0/2 to 10 V, resp. 10 to 0/2 V

electronic positional transmitter (EPV) without power supply (passive).....18 up to 30 V DC $\pm 10\%$

communication protocol (by version).....Modbus (either single Channel or duo Channel)

Frequency of power supply 50/60* Hz $\pm 2\%$

* At frequency of 60 Hz operating time is reduced by 1.2 times.

Duty cycle (according to EN 60034-1,8 (IEC 60034-1, 8):

EA SPR PA are designed for :

- remote control:

- short-time operation **S2-10 min**
- intermitted operation **S4-25%, 6 up to 90 cycles per hour**

- automatic regulation:

- intermitted operation **S4-25%, 90 up to 1200 cycles per hour**

Note:

The operation modes consist of the loading type, load factor and connection/switching frequency.

Warning: Non-compliance with operating mode may result in inactivation of the EA as a result of failure of the integrated thermal fuse (protection) of the electric motor.

1.8 Description and function

EA **SPR PA** is controlled by version:

- by supplying the 24 V DC current to EA terminals according to a wiring diagram or
- with the input control signal 0/4/12 to 20 mA, 4 to 12 mA (0/2 to 10 V) (it allows automatic setting of the position of the EA output relay in relation to the value of the input signal) and provides also other functions.
- through Modbus communication interface.

The electric actuator consists of these main parts (**Fig. 1, 1A**):

The electric actuator is driven by an **electric motor (1)** supplied and controlled from the **source board (3)** and **control unit (2)** of the DMS3 electronics.

Position of output element of EA and torque are scanned by contactless absolute sensor.

Depending on the version, the DMS3 electronic circuit board may include an **electronic position switch (EPV)**:

- without power supply (passive) with output signal 4 - 20 mA.
- with power supply (active) with output signal 4 to 20 mA, with voltage supply from an internal source.

Space heater is placed at the control board. (5).

In case of power cut or damage of switches the actuator can be controlled manually according to instructions stated in chapter 4 Service, maintenance and troubleshooting.

Basic modules of DMS3 electronic control system for SPR PA:

Control unit (2) – main part of system DMS3 – it contains microprocessor, 6 signal LED and 4 buttons for simple adjustment and control of EA, connectors for connection of torque scanner and sourcing board and communication connector (connection to PC for adjustment and diagnostic), by version 2 free programmable relays R1 and R2, 1 relay READY and terminals for electric connection.

Sourcing board for single - phase version (3) – secures power supply of electronic and provides an output voltage of 24 V DC, 40 mA for the user (by version), it contains user terminal board, switching circuits, connector for connection with control unit.

Position scanning unit (4) – secures contactless magnetic position scanning of output element.

Torque reading unit (6) – provides contactless magnetic torque reading.

Switching unit three - phase electric motors – reversing relays, contactors or contactless switching (SSR).

LED display (7) – shows instant position of EA output member and reports and displays potential errors which would occur when EA is operated. Signalling motion and failure of the EA is also indicated by LEDs diode. LED display is used only pro type of construction EA without local control.

Manual control: made up by a handwheel with a worm gearing.

Other accessories – as optional accessories:

- **Module 3, or 6 additional relays, (by version),(8).**
- Local electric control module equipped with a 2-line LCD display (Fig. 7).

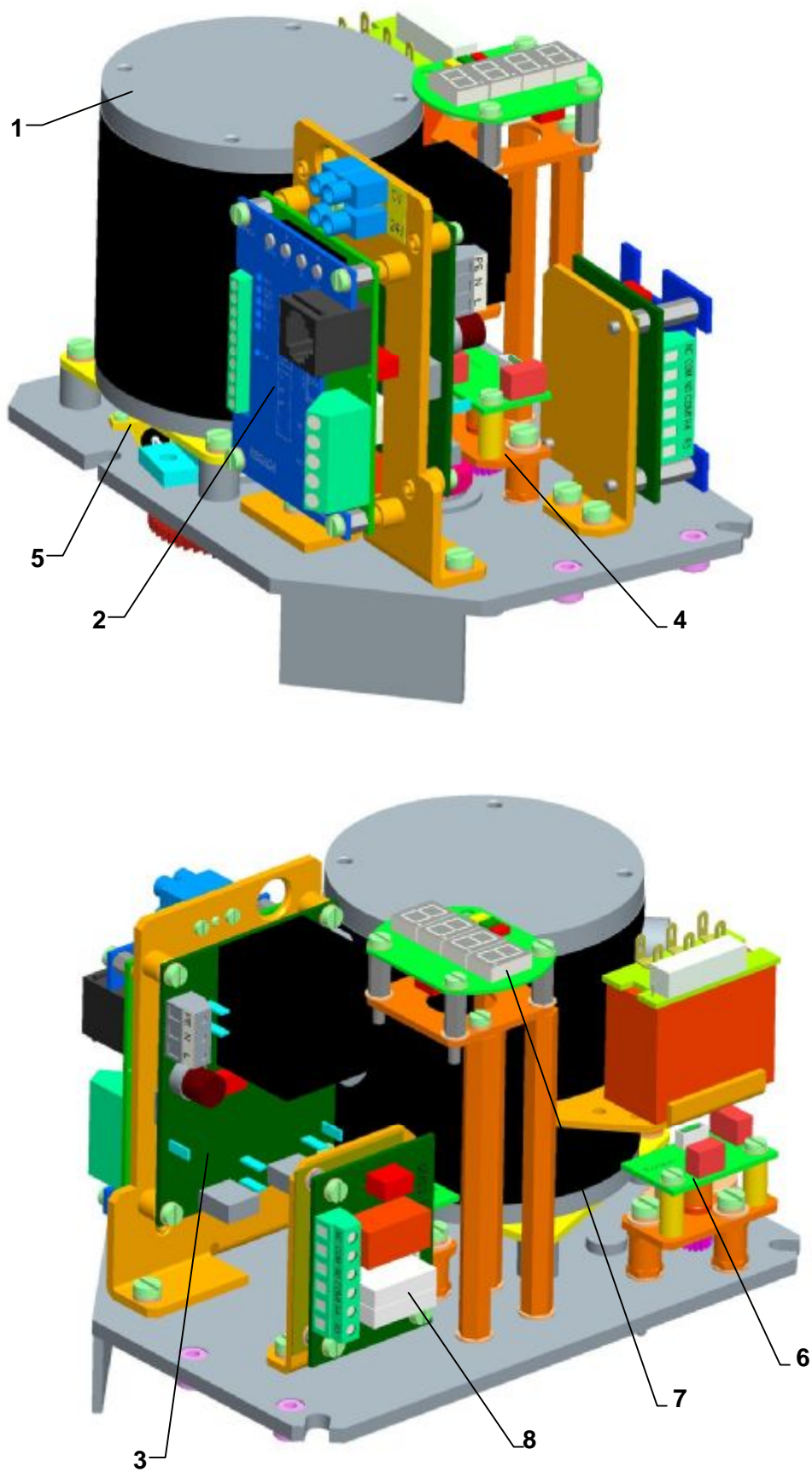

Fig. 1

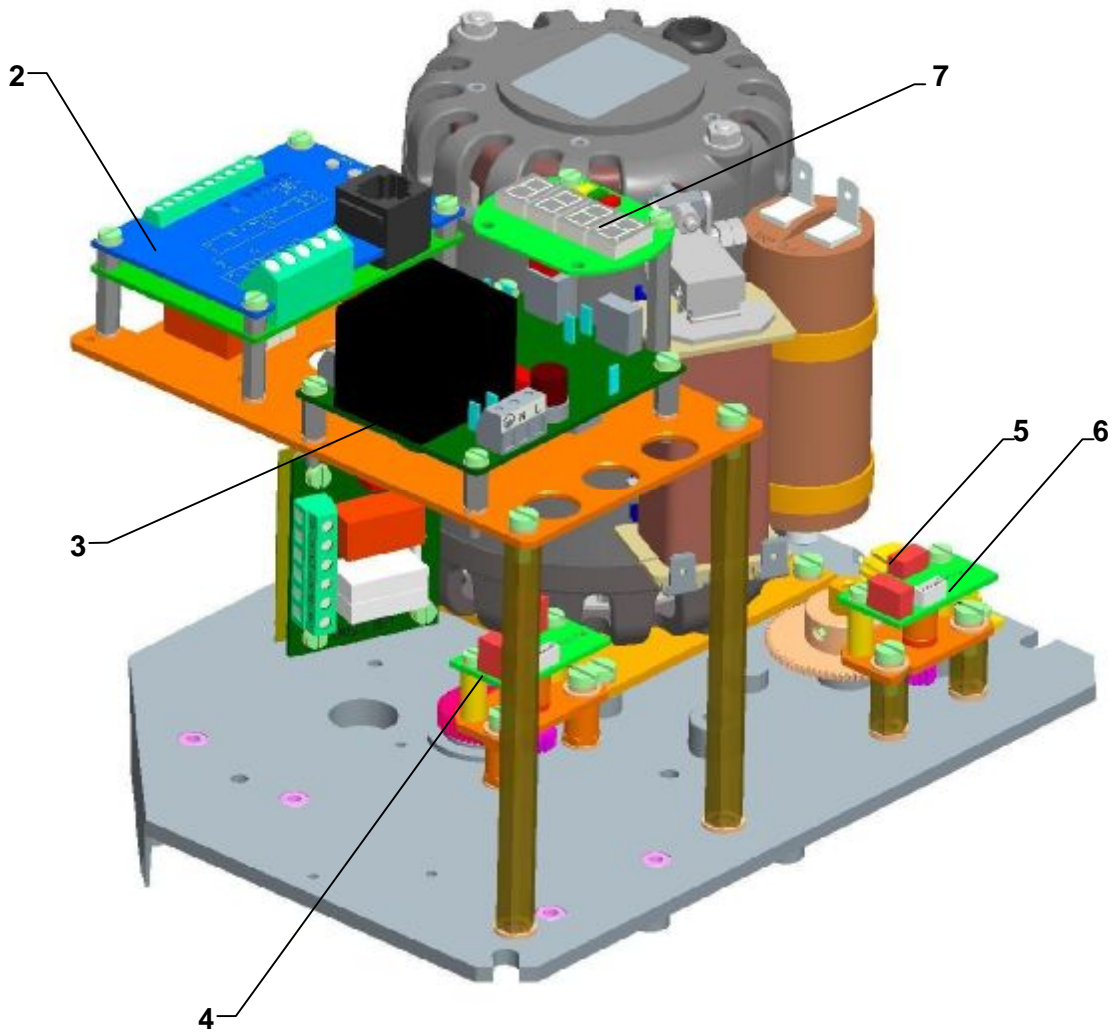

Fig. 1A

1.9 Basic specifications

Basic EA specifications:

Max. load torque [Nm], Operating time[s/90°], Operating angle [°], Switching-off torque [Nm] and electric motor parameters are given in Table 1.

| Table 1 - Basic Specifications | | | | | | | | | | | | | | | | | |
|--------------------------------|----------------------|-------|---|------------------------------------|-----------------------------------|----------------------------------|-------------|--|--|-------|-----------|--------------------|-----------------|----|------|------|---|
| Type Number | Operating time±10[%] | | Operating angle | Max. load torque (regulation mode) | Max. load torque (remote control) | Switching-off torque ±10 [%][Nm] | Weight | Electric motor | | | | | | | | | |
| | | | | | | | | Power supply nominal voltage / frequency | Nominal | | | Capacitor capacity | | | | | |
| | | | | | | | | | power | speed | current | | | | | | |
| | [s/90°] | [°] | [Nm] | [Nm] | [Nm] | [kg] | [V/Hz] | [W] | [1/min] | [A] | [µF/V] | | | | | | |
| | 50 Hz | 60 Hz | | | | | | | | | | | | | | | |
| 1 | 2 | 3 | 4 | 5 | 6 | 7 | 8 | 9 | 10 | 11 | 12 | 13 | 14 | | | | |
| SPR 1 PA Type Nr. 231 | 10 | 8 | 60°, 90°, 120°, 160° with stop ends ¹⁾ | - | 40 | 46 | 6,6 – 8,0 | Single - phase | 24/50-60 120/60 220/50 230/50 240/60 | 15/18 | 2750/3350 | 2,1 | 150/63 | | | | |
| | 20 | 17 | | 63 | 80 | 80 | | | | 18 | 3350 | 0,44 | 6/250 | | | | |
| | 40 | 34 | | 50 | 63 | 72 | | | | 15 | 2750 | 0,28 | 2,2/350 | | | | |
| | 80 | 66 | | 50 | 63 | 72 | | | | 15 | 2750 | 0,28 | 2,2/350 | | | | |
| | | | | | | | | | | 18 | 3350 | 0,22 | 1,5/400 | | | | |
| | | | | | | | | | | 4/5 | 1270/1630 | 1,3/1,3 | 150/63 | | | | |
| | 5 | 6 | | 5 | 63 | 72 | | | | 5 | 1630 | 0,24 | 6/250 | | | | |
| | 4 | 5 | | 4 | 63 | 72 | | | | 4 | 1270 | 0,14 | 2,2/350 | | | | |
| | 4 | 5 | | 4 | 63 | 72 | | | | 4 | 1270 | 0,14 | 2,2/350 | | | | |
| | 5 | 6 | | 5 | 63 | 72 | | | | 5 | 1630 | 0,13 | 1,5/400 | | | | |
| SPR 2PA Type Nr. 232 | 5 | 4 | 60°, 90°, 120°, 160° with stop ends ¹⁾ | - | 63 | 72 | 12,0 – 14,5 | Single - phase | 120/60 220/50 230/50 240/60 | 70 | 3380 | 1,00 | 16/250 | | | | |
| | 10 | 8 | | 100 | 125 | 145 | | | | 60 | 2750 | 0,70 | 7/400 | | | | |
| | 20 | 17 | | | | | | | | 60 | 2750 | 0,70 | 7/400 | | | | |
| | 40 | 34 | | | | | | | | 70 | 3380 | 0,65 | 5/450 | | | | |
| | 80 | 66 | | 100 | 125 | 145 | | | | 25 | 1680 | 0,80 | 20/300 | | | | |
| | | | | | | | | | | 20 | 1350 | 0,50 | 7/400 | | | | |
| | | | | | | | | | | 20 | 1350 | 0,50 | 7/400 | | | | |
| | 25 | 1680 | | 0,40 | 5/450 | | | | | | | | | | | | |
| | 5 | 4 | | - | 63 | 72 | | | | | | Three - phase | 3x400/ 3x380 | | | | |
| | 10 | 8 | | 100 | 125 | 145 | | | | | | | | 90 | 2740 | 0,35 | - |
| 20 | 17 | | | | | | | | | | | | | | | | |
| 40 | 34 | | | | | | | | | | | | | | | | |
| 80 | 66 | | | | | | | | | | | | | | | | |

| Table 1 - Basic Specifications - continue | | | | | | | | | | | | | | | | | | |
|---|-----------------------------|---|---|------------------------------------|-----------------------------------|---------------------------------------|---------------|--|--------------------------------------|--------------------------------------|---------|--------------------|--------|--------|------|-------|------|-------|
| Type Number | Operating time ± 10 [%] | | Operating angle | Max. load torque (regulation mode) | Max. load torque (remote control) | Switching-off torque ± 10 [%][Nm] | Weight | Electric motor | | | | | | | | | | |
| | | | | | | | | Power supply nominal voltage / frequency | Nominal | | | Capacitor capacity | | | | | | |
| | | | | | | | | | power | speed | current | | | | | | | |
| | [s/90°] | | [°] | [Nm] | [Nm] | [Nm] | [kg] | [V/Hz] | [W] | [1/min] | [A] | [μ F/V] | | | | | | |
| SPR 2.3PA Type Nr. 233 | 20 | 17 | 60°, 90°, 120°, 160° with stop ends ¹⁾ | 200 | 250 | 290 | 17,0 - 17,5 | Single-phase | 120/60 220/50 230/50 240/60 | 70 | 3380 | 1,00 | 16/250 | | | | | |
| | 40 | 34 | | | | | | | | 60 | 2750 | 0,70 | 7/400 | | | | | |
| | | | | | | | | | | 60 | 2750 | 0,70 | 7/400 | | | | | |
| | | | | | | | | | | 70 | 3380 | 0,65 | 4/450 | | | | | |
| | 80 | 66 | | | | | | | 25 | 1680 | 0,80 | 20/300 | | | | | | |
| | 160 | 135 | | | | | | | | | | | 20 | 1350 | 0,50 | 7/400 | | |
| | | | | | | | | | | | | | 20 | 1350 | 0,50 | 7/400 | | |
| | | | | | | | | | | | | | 25 | 1680 | 0,40 | 5/450 | | |
| 20 | 17 | 60°, 90°, 120°, 160° with stop ends ¹⁾ | 400 | 500 | 575 | 20,5 - 21,0 | Three - phase | 3x400/ 3x380 | 90 | 2740 | 0,35 | - | | | | | | |
| 40 | 34 | | | | | | | | Single-phase | 120/60 220/50 230/50 240/60 | 70 | 3380 | 1,00 | 16/250 | | | | |
| 80 | 66 | | | | | | | | | | 60 | 2750 | 0,70 | 7/400 | | | | |
| | | | | | | | | | | | 60 | 2750 | 0,70 | 7/400 | | | | |
| | | | | | | | | | | | 70 | 3380 | 0,65 | 4/450 | | | | |
| 160 | 135 | | | | | | | | | | 25 | 1680 | 0,80 | 20/300 | | | | |
| | | | | | | | | | | | | | | | 20 | 1350 | 0,50 | 7/400 |
| | | | | | | | | | | | | | | | 20 | 1350 | 0,50 | 7/400 |
| | | 25 | 1680 | 0,40 | 5/450 | | | | | | | | | | | | | |
| 40 | 34 | 60°, 90°, 120°, 160° with stop ends ¹⁾ | 400 | 500 | 575 | 20,5 - 21,0 | Single-phase | 3x400/ 3x380 | 90 | 2740 | 0,35 | - | | | | | | |
| 80 | 66 | | | | | | | | Single-phase | 120/60 220/50 230/50 240/60 | 70 | 3380 | 1,00 | 16/250 | | | | |
| | | | | | | | | | | | 60 | 2750 | 0,70 | 7/400 | | | | |
| | | | | | | | | | | | 60 | 2750 | 0,70 | 7/400 | | | | |
| 160 | 135 | | | | | | | | | | 25 | 1680 | 0,80 | 20/300 | | | | |
| | | | | | | | | | | | | | | | 20 | 1350 | 0,50 | 7/400 |
| | | | | | | | | | | | | | | | 20 | 1350 | 0,50 | 7/400 |
| | | | | | | | | | | | | | | | 25 | 1680 | 0,40 | 5/450 |

1) EA version without stops has the possibility to set up the output angle within the ranges 50° to 120°, 90° to 160°, 160° to 360° in accordance with EA specification.

EA protection enclosure: IP 67 EN 60 529 (IEC 60 529)

Mechanical ruggedness:

sinusoid vibrations see Chapter 1.7.2

resistance by drops 300 drops with acceleration of 5 m.s⁻²

seismic resistance 6 degrees of Richter's scale

Self-locking: guaranteed within 0% till 100% load torque (with mechanical or electric- magnetic brake)

Electric motor protection: through the Thermik 01.135.5 thermo-contact

EA braking: SPR 1 PA with mechanical brake
..... or with electric-magnetic brake

Electric control:

remote control movement of output part of the electric actuator is controlled :

- by binary inputs 24 V DC, or

by unified input signal 0/4/12 to 20 mA, 4 to 12 mA, resp. 0/2 to 10 V by version

- potentially controlled through a interface with Modbus communication protocol

Power supply of electronics:

- power supply ZS
- it provides the 24V DC, 40 mA output voltage (by version)

Power sources contain a protective fuse with parameters according to chapter 1.9.2 Electric connection

Position scanning:

- contactless absolute magnetic

End positions adjustment:

End position relays are adjusted with accuracy to specific operating angle $\pm 2^\circ$.

It is possible to set up (with keys situated on the control unit or through with keys situated on the electric local control, resp. program after connecting the EA with PC) the switching-off in end positions as follows:

- C = Torque + O = Torque
- C = Torque + O = Position
- C = Position + O = Torque
- C = Position + O = Position

Notes:

- C = Torque - shutting off at end limit - torque „Closed“
- O = Torque - shutting off at end limit - torque „Opened“
- C = Position - shutting off at end limit - position „Closed “
- O = Position - shutting off at end limit - position „Opened“

Factory's setup of switching-off in end positions is described in the chapter "Adjusting of actuator".

Torque scanning:

- contactless absolute magnetic

Disengaging torque adjusting:

Disengaging torque is factory adjusting to a maximum value with the $\pm 10\%$ tolerance shown on the nameplate of the appropriate EA.

The user is allowed to modify the switching-off torque value within the range 50 - 100%, stepped by 10%.

Torque blocking:

The switching-off from torque can be blocked within a certain range of the stroke starting from a stroke end position (max.5%), for time agreed on, in range of 0 to 20 sec..

Output relay (by version):

- 3x relays (standard for DMS3 without version Modbus) (READY, R1, R2) max. 250 V AC/1 A/cos phi=1; max. 30 V DC/2A
- 3x additional relays (options) (RE3, RE4, RE5) max. 250 V AC/1 A/cos phi=1; max. 30 V DC/2A
- 6x additional relays (options) (RE1, RE2, RE3, RE4, RE5, READY) max. 250 V AC/1 A/cos phi=1; max. 30 V DC/2A
- relays READY, R1, R2, RE3, RE4 and RE5 are free programmable (their function can be changed with buttons on the control unit, with buttons on the electric local control, or through a PC with the program).

READY relay: - programme selections option – error indication, error or warning, error or not remote, error or warning or not remote. READY relay factory set is shown in the "Adjusting of actuator" Chapter. Relay READY on the control unit and supply unit are doubled (it is not possible to set different functions on these units).

R1, R2, RE1, RE 2, RE3, RE4 and RE5 relay: - programme selections option – disabled, Position O (position open), Position C (position close), Torque O (torque open), Torque C (torque close), Torque O or Torque C, Torque O or Position O, Torque C or Position C, opens, closes, movement, movement – flasher, to position, from position, warning, control – remote, control – local, (not valid for EA without local control), control OFF.

Relay R1 is doubled with relay RE1 and relay R2 is doubled with relay RE2 (it is not possible to set different functions on these units).

RE3, RE4, RE5 relays are independent. Factory setting up of the individual relays is shown in the "Adjusting of actuator" Chapter.

Transmitter (output signal)(not valid for Modbus version)

Electronic position transmitter (EPV) passive (for single - phase versions)- 2-wire connection (without inbuilt power supply)

| | |
|---|------------------------------|
| Current signal | 4 ÷ 20, resp. 20 ÷ 4 mA (DC) |
| Voltage at connection of EPV passive | 18 up to 30 V DC |
| Load resistance | max. $R_L = 500 \Omega$ |
| Tolerance of value of output signal of electronic transmitter in end positions: | $\pm 0,5 \%^{1)}$ |
| Tolerance of linearity of transmitter | $\pm 1 [\%]^{1)}$ |
| Hysteresis of transmitter | max. 1 $[\%]^{1)}$ |

1) from nominal value of transmitter referred to output values

Galvanic separation output signal is galvanically separated from input control signal

Program possibilities of output signal (N) : 4 ÷ 20 mA, 20 ÷ 4 mA . Factory's setup of output signal is described in the chapter "Adjusting of actuator".

Electronic position controller (N) – (not valid for Modbus version) - actuation by input control signal

| | |
|--|---------------------------------|
| Input control signals - analogue:..... | 0 - 20 mA (0 – 10 V by version) |
| | 4 - 20 mA (2 – 10 V by version) |
| | 2 - 20 mA |
| | 4 - 12 mA |
| | 20 - 0 mA (10 – 0 V by version) |
| | 20 - 4 mA (10 – 2 V by version) |
| | 20 - 12 mA |
| | 12 - 4 mA |
| Input resistance for signal 0/4/12 to 20 mA. 4 to 12 mA: | $R_{in} = 120 \Omega$ |
| Input resistance for signal 0/2 to 10 V: | $R_{in} = 30 k\Omega$ |
| Tolerance of controller's linearity: | 0,5 % |
| Dead of controller: | 1 – 10 % - (adjustable) |

Factory's setup of input signal is described in the chapter "Adjusting of actuator".

Version with Modbus interface:

- Modbus, line specification: RS485, two-wire design, half duplex.
- Modbus, Transmission Mode: RTU (8-bit binary data).
- Variants:
 - Single Channel version
 - Duo Channel version with cable or component redundancy or with repeater (common address and communication parameters).
- Address: 1 through 247
- Parity:
 - Even (1 stop bit)
 - Odd (1 stop bit)
 - No (2 stop bits)
- Supported transmission rates:
 - 300 bit/s
 - 600 bit/s
 - 1200 bit/s
 - 2400 bit/s
 - 4800 bit/s
 - 9600 bit/s
 - 19200 bit/s
 - 38400 bit/s
 - 57600 bit/s
 - 115200 bit/s
- Signal delay (repeater):
 - max. 2.67 μs
- Bit edge reduction/extension (repeater):
 - max. 1.67 μs

Control by binary inputs 24 V DC:

by feeding of 24 V DC to terminals CLOSE and OPEN.

Programming possibilities of binary inputs I1 and I2 (change is possible only through the programme of PC or using buttons local control):

- for the input I1 : DISABLED; ESD; DBL (local releasing, remote releasing - not valid for this type of the EA); STOP
 - for the input I2: DISABLED; ESD; DBL (local releasing, remote releasing - not valid for this type of the EA); 2P, resp. E2P (the EA can undergo control for the opening direction or closing with the controller ON and I2 input activated with 24 V DC voltage supplied to the terminals to OPEN or CLOSE).
- Factory's setup is described in the chapter "Adjusting of actuator".

Programmable FAILURE REACTION: OPEN, CLOSE, STOP, SAFE POSITION

Factory's setup is described in the chapter "Adjusting of actuator".

Adjustable elements :

The EA is possible to adjust with or resetting to different parameters operating the control unit buttons, local control buttons (following the version) or once it is connected to the PC using the programme and the communication cable connected to the EA control unit communication connector and the EA cover removed.

Space heater (E1)

- Space heater - supply voltage:corresponding with motor supply voltage (max. 250 V AC)
- Space heater power output: SPR 1PA cca 10 W/55°C
- SPR 2PA - SPR 2.4PA (230 V AC) cca 20 W/55°C

Electronic board provides switching of heating element. It is possible to change switching temperatures of the switch from -40°C to +70°C with help of PC and particular software. Factory's setup for shut down of heating element (thermostat) is +25°C.

Manual control:

- operate the **handwheel** with the motor running. Turning the hand wheel clockwise causes the electric actuator output shaft to move in "Z" direction.

Output part backlash: max. 1° (at 5 % of maximum switching torque load)

Grease: see chapter 4.2 Maintenance - extent and periodicity.

1.9.1 Mechanical Connection

- with flanges (ISO 5211)

Main and connecting dimensions are given in the **dimensional drawings**.

1.9.2 Electric connection

To the terminal board (X, X1, X2) for DMS 3 version:

- 3 terminals (PE, N, L) on the sourcing board with cross-section of connection wire 0,05 - 1,5 mm² for solid wire and for flexible wire. Max. terminal screw tightening torque 0,5 N.m
- 3 terminals ((2(L1), 3(L2), 4(L3)) – for version with three - phase electric motor) with intersection of connection wire max. 1,5 mm². Max. terminal screw tightening torque 0,285 N.m.
- 4 terminals ((5,6,OP,CL) – for version with three - phase electric motor without reverse unit) with intersection of connection wire max. 1,5 mm². Max. terminal screw tightening torque 0,285 N.m.
- 2 terminals (0 V,+24 V) with cross-section of cross-section wire max. 1,5 mm². Max. terminal screw tightening torque 0,285 N.m.
- 5 terminals (READY, R1, R2) with cross-section of connection wire 0,05 – 1,5 mm² for solid wire and for flexible wire. Max. terminal screw tightening torque 0,5 N.m
- 10 terminals (COM, CLOSE, OPEN, I1, I2, +IN,-IN,SH,+L,-L) with cross-section of connection wire 0,05 – 1 mm² for solid wire and for flexible wire. Max. terminal screw tightening torque 0,19 N.m.
- 6 terminals (COM1, RE3, RE4, COM5, NO5, NC5) - for module 3 additional relays with cross-section of connection wire 0,05 – 1,5 mm² for solid wire and for flexible wire. Max. terminal screw tightening torque 0,5 N.m.
- 11 terminals (COM1, RE1, RE2, RE3, RE4, COM5, NO5, NC5, COM, NO, NC - for module 6 additional relays with intersection of connection wire 0,05 – 1,5 mm² for solid wire and for flexible wire. Max. terminal screw tightening torque 0,5 N.m.

To the terminal board (X3) for DMS3 with MODBUS protocol:

Terminal boards with spring connection are used, with cross-section of connection wire 0,08 to 2,5 mm²

- 3 terminals (PE, N, U) – supply voltage for version with single - phase
- 5 terminals (PE, N, U, V, W) – voltage for version with three - phase
- 2 terminals (21, 22) – voltage for the 24 V DC control

- 10 terminals (13,14,15,16,17) – terminals for the 24 V DC control (COM,CLOSE,OPEN, I1, I2)
- 6 terminals (1,2,3,4,5,6) – terminals single Channel interface of version Modbus
- 6 terminals (7,8,9,10,11,12) - terminals redundant of version Modbus (by version)
- 3 terminals (18,19,20) – module relay READY (by version)
- 5 terminals (18,19,20,23,24) – module additional relays (by version)

Attention: Thermic resistance incoming wires must be minimum +80°C

| Wire cross-section conversion table (mm ² – AWG) | |
|---|-----|
| Wire cross-section | |
| mm ² | AWG |
| 0,05 | 30 |
| 0,2 | 24 |
| 0,34 | 22 |
| 0,5 | 20 |
| 0,75 | 18 |
| 1,5 | 16 |
| 2,5 | 14 |

| Tightening torque conversion table (N.m – lbs.-in) | |
|--|---------|
| Tightening torque | |
| N.m | lbs.-in |
| 0,2 | 2,7 |
| 0,3 | 4 |
| 0,5 | 7 |

Cable glands for EA with the DMS 3 electronic control

Cable glands for the model without electric local control:

- 3 cable glands – 1xM12 - cable diameter 3,5 to 5 mm, 1xM16 - cable diameter 9 to 13 mm and 1xM20 - cable diameter 8 to 14,5 mm – valid for EA SPR 1PA
- 3 cable glands – 1xM16 - cable diameter 6 to 10,5 mm, 1xM16 - cable diameter 9 to 13 mm and 1xM20 - cable diameter 8 to 14,5 mm – valid for EA SPR 2PA, SPR 2.3PA and SPR 2.4PA.

Cable glands for the model with electric local control:

- 2 cable glands – 1xM12 - cable diameter 3,5 to 5 mm and 1xM16 - cable diameter 9 to 13 mm – for SPR 1PA
- 2 cable glands - 1xM16 - cable diameter 6 to 10,5 mm and 1xM16 - cable diameter 9 to 13 mm – for SPR 2PA, SPR 2.3PA and SPR 2.4PA.

Cable glands for EA with the DMS 3 electronic control with MODBUS protocol

- 2 cable glands M20x1,5, cable diameter 8 to 14,5 mm
- 2 resp. 4 cable glands EMC M16x1,5 - cable diameter 6,5 to 9,5 mm, diameter of shielding 2,5 to 6mm.

There must be included power switch or motor circuit breaker to the power supply, which should be selected according to the electric motor power for the output parameters according to Table 2 (e.g. motor-overcurrent circuit breaker MIS 32 - ... manufacturer SEZ; P25M manufacturer Schneider respectively PKZM01.... fy Eaton). It must be placed as close as possible to the device, easily accesible to the operator and marked as an disconnecting device of actuator.

| Table selection of fuse to electric motor | | | | | | |
|---|-------------------------|-------------------------|-------------|-------------|----------------|-------------------------------------|
| Single-phase | Three - phase | | | | | Adjustable range of circuit-breaker |
| 220 V 230 V 240 V | 220 V 230 V 240 V | 380 V 400 V 415 V | 440 V | 500 V | 660 V 690 V | |
| (kW) | | | | | | (A) |
| | 0,06 | 0,09 | 0,09...0,12 | 0,09...0,12 | 0,18 | 0,25 ... 0,4 |
| - | 0,09 | 0,12...0,18 | 0,18 | 0,18 | 0,25 | 0,4...0,63 |
| 0,06...0,09 | 0,09...0,12 | 0,18...0,25 | 0,25...0,37 | 0,25...0,37 | 0,37...0,55 | 0,63...1 |

External and internal, are together connected and marked with the mark of protection grounding.
The electric connection should be made according to wiring diagrams pasted into the upper cover of the EA.

Protection terminal:

During start-up - during installation of device:



- for safety operation of the actuator use EA be unavoidable connect external and internal ground terminal (by version EA.) The position of the external a internal ground terminal can be seen in Fig. 2, 2a, 2b, 2c, 2d. For forcing - in wires in external ground terminal be needed use pliers HP3 for insulated eyelet (firm CEMBRE).

- a switch / circuit breaker must be installed on the power supply line, as close as possible to the device, easily accessible to operators and identified as the actuator isolation switch.

External and internal, are together connected and marked with the mark of protection grounding.

The electric connection should be made according to wiring diagrams pasted into the upper cover of the EA.

Fuses:

Actuator power supply board is installed with power supply fuse (F3). Location of the fuse on the power supply board can be seen in Fig.2.

EA's equipped with a contactless switching module (SSR) are protected with fuses (F4-1 and F4-2) on a holder (Fig. 2e).

Fuse values and parameters:

| Product | Order code | Voltage | Frequency (Hz) | Motor Power / Input (W) | max. Current EA (A) | Fuse F3 value | Fuse value only for version with SSR) F4-1 F4-2 |
|----------------|----------------|------------|----------------|-------------------------|---------------------|------------------|---|
| SPR 1PA 231 | 231.1-0XXXX/YY | 220/230 | 50 | 4/25 | 0,2 | F 2,5 A / 250 V | - |
| | 231.1-VXXXX/YY | 240 VAC | 60 | 5/28 | | | |
| | 231.1-TXXXX/YY | 110/120VA | 60 | 5/28 | 0,4 | F 2,5 A / 250 V | - |
| | 231.1-3XXXX/YY | 24 VAC | 50 | 4/25 | 1,9 | T 2 A / 250 V | - |
| | 231.1-JXXXX/YY | 24 VAC | 60 | 5/28 | | | |
| | 231.1-0XXXX/YY | 220/230 | 50 | 15/39 | 0,3 | F 2,5 A / 250 V | - |
| | 231.1-VXXXX/YY | 240 VAC | 60 | 18/48 | | | |
| | 231.1-TXXXX/YY | 110/120VA | 60 | 18/48 | 0,6 | F 2,5 A / 250 V | - |
| | 231.1-3XXXX/YY | 24 VAC | 50 | 15/39 | 2,8 | T 3,15 A / 250 V | - |
| | 231.1-JXXXX/YY | 24 VAC | 60 | 18/48 | | | - |
| | 231.1-MXXXX/YY | 3x380 V AC | 50 | 15/40 | xx | F 2,5 A / 250 V | - |
| | 231.1-1XXXX/YY | 3x400 V AC | 50 | 15/40 | xx | | - |
| | 231.1-NXXXX/YY | 3x380 V AC | 50 | 15/40 | xx | F 2,5 A / 250 V | - |
| | 231.1-2XXXX/YY | 3x400 V AC | 50 | 15/40 | xx | | |
| SPR 2PA 232 | 232.1-0XXXX/YY | 220/230 | 50 | 20/75 | 0,45 | F 2,5 A / 250 V | - |
| | 232.1-VXXXX/YY | 240 VAC | 60 | 25/70 | | | |
| | 232.1-TXXXX/YY | 110/120VA | 60 | 25/70 | 1,0 | F 2,5 A / 250 V | - |
| | 232.1-0XXXX/YY | 220/230 | 50 | 60/120 | 0,9 | F 2,5 A / 250 V | - |
| | 232.1-VXXXX/YY | 240 VAC | 60 | 70/125 | 0,52 | F 2,5 A / 250 V | - |
| | 232.1-TXXXX/YY | 110/120VA | 60 | | 1,3 | F 2,5 A / 250 V | - |
| | 232.1-MXXXX/YY | 3x380 V AC | 50 | 90/150 | 0,5 | F 2,5 A / 250 V | FF 3,15A/500V |
| | 232.1-1XXXX/YY | 3x380 V AC | 50 | 90/150 | 0,5 | F 2,5 A / 250 V | |
| | 232.1-NXXXX/YY | 3x400 V AC | 50 | 90/150 | 0,5 | F 2,5 A / 250 V | |
| | 232.1-2XXXX/YY | 3x400 V AC | 50 | 90/150 | 0,5 | F 2,5 A / 250 V | |

| Product | Order code | Voltage | Frequency (Hz) | Motor Power / Input (W) | max. Current EA (A) | Fuse F3 value | Fuse value only for version with SSR) F4-1 F4-2 |
|------------------|----------------|------------|----------------|-------------------------|---------------------|-----------------|---|
| SPR 2.3PA 233 | 233.1-0XXXX/YY | 220/230 | 50 | 20/75 | 0,45 | F 2,5 A / 250 V | - |
| | 233.1-VXXXX/YY | 240 VAC | 60 | 25/70 | | | |
| | 233.1-TXXXX/YY | 110/120VA | 60 | 25/70 | 1,0 | F 2,5 A / 250 V | - |
| | 233.1-0XXXX/YY | 220/230 | 50 | 60/120 | 0,9 | F 2,5 A / 250 V | - |
| | 233.1-VXXXX/YY | 240 VAC | 60 | 70/125 | 0,52 | F 2,5 A / 250 V | - |
| | 233.1-TXXXX/YY | 110/120VA | 60 | | 1,3 | F 2,5 A / 250 V | - |
| | 233.1-MXXXX/YY | 3x380 V AC | 50 | 90/150 | 0,5 | F 2,5 A / 250 V | FF 3,15A/500V |
| | 233.1-1XXXX/YY | 3x380 V AC | 50 | 90/150 | 0,5 | F 2,5 A / 250 V | |
| | 233.1-NXXXX/YY | 3x400 V AC | 50 | 90/150 | 0,5 | F 2,5 A / 250 V | |
| | 233.1-2XXXX/YY | 3x400 V AC | 50 | 90/150 | 0,5 | F 2,5 A / 250 V | |
| SPR 2.4PA 234 | 234.1-0XXXX/YY | 220/230 | 50 | 20/75 | 0,45 | F 2,5 A / 250 V | - |
| | 234.1-VXXXX/YY | 240 VAC | 60 | 25/70 | | | |
| | 234.1-TXXXX/YY | 110/120VA | 60 | 25/70 | 1,0 | F 2,5 A / 250 V | - |
| | 234.1-0XXXX/YY | 220/230 | 50 | 60/120 | 0,9 | F 2,5 A / 250 V | - |
| | 234.1-VXXXX/YY | 240 VAC | 60 | 70/125 | 0,52 | F 2,5 A / 250 V | - |
| | 234.1-TXXXX/YY | 110/120VA | 60 | | 1,3 | F 2,5 A / 250 V | - |
| | 234.1-MXXXX/YY | 3x380 V AC | 50 | 90/150 | 0,5 | F 2,5 A / 250 V | FF 3,15A/500V |
| | 234.1-1XXXX/YY | 3x380 V AC | 50 | 90/150 | 0,5 | F 2,5 A / 250 V | |
| | 234.1-NXXXX/YY | 3x400 V AC | 50 | 90/150 | 0,5 | F 2,5 A / 250 V | |
| | 234.1-2XXXX/YY | 3x400 V AC | 50 | 90/150 | 0,5 | F 2,5 A / 250 V | |

INTERNAL
PROTECTION
TERMINAL FOR
SINGLE PHASE
VERSIONS

FUSE SUPPLY
(F3)

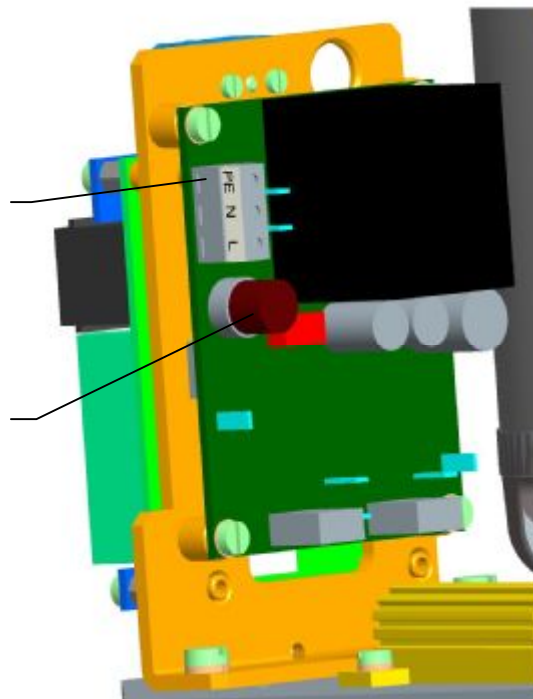

Fig.2

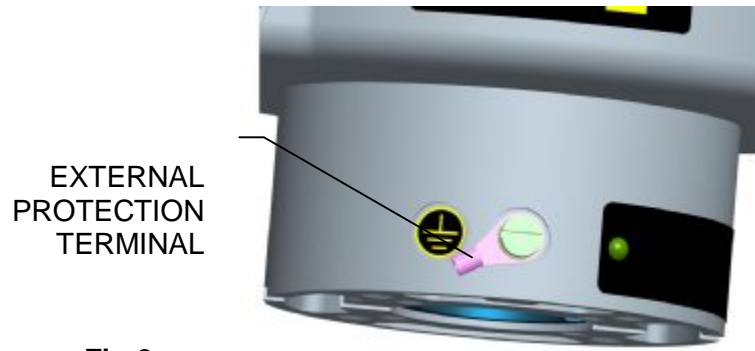

Fig.2a

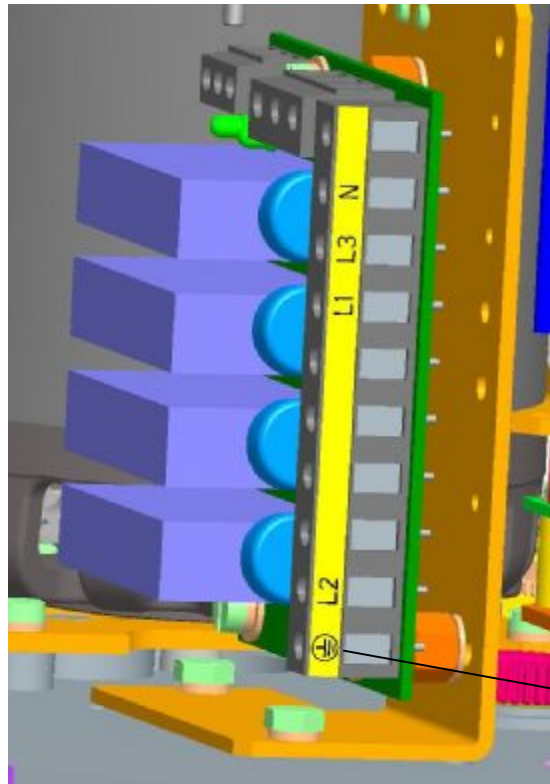

Fig.2b

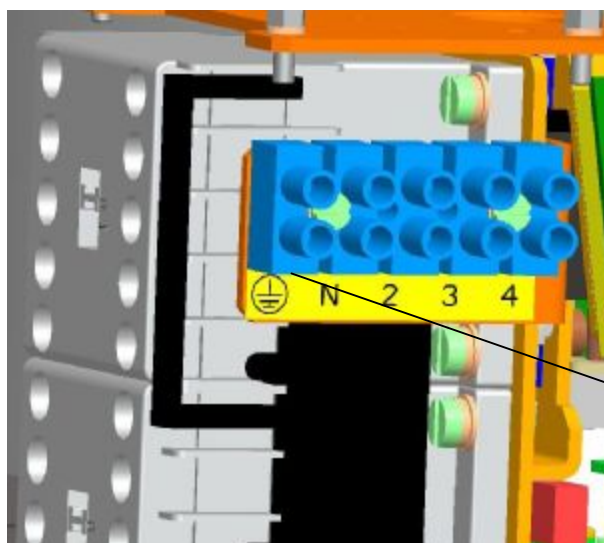
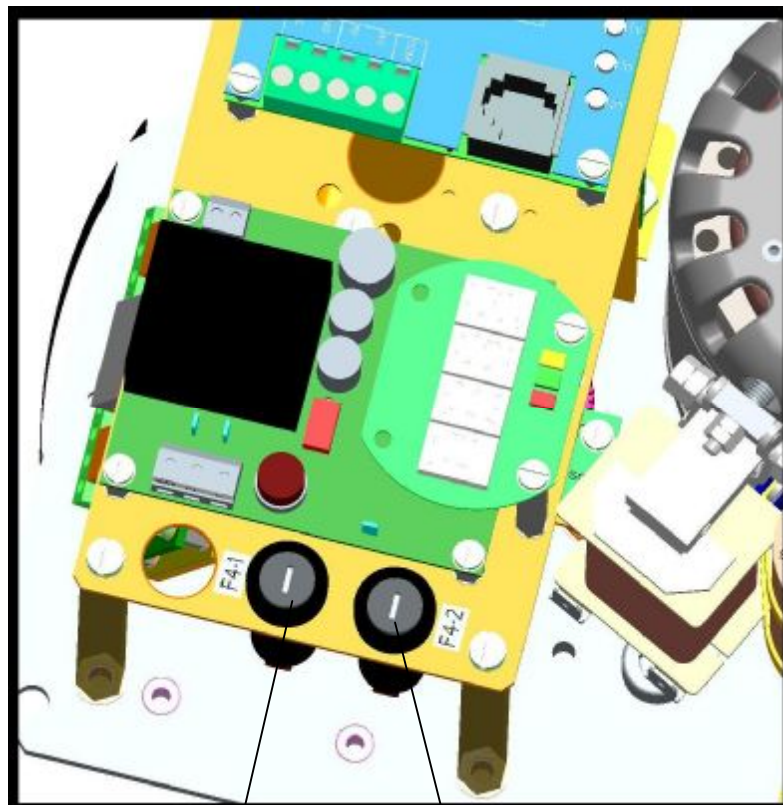
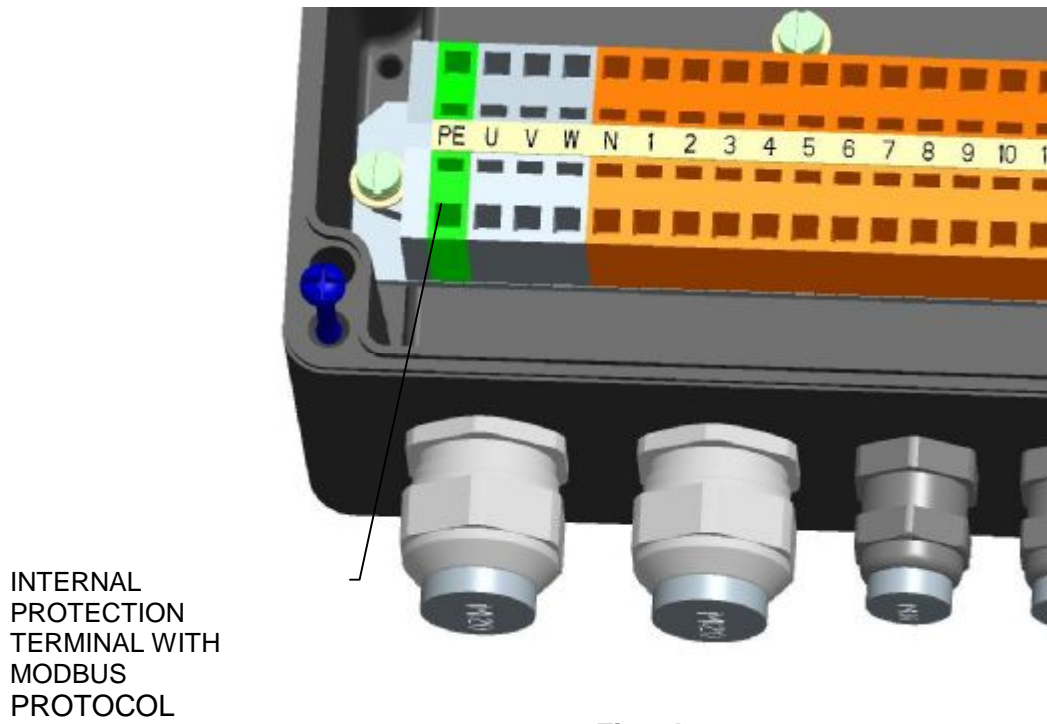

Fig.2c



FUSE F4-1

FUSE F4-2

1.10 Packing, transport, storing and unpacking

The EA SPR PA are delivered in solid packages guaranteeing resistance in accordance with EN (IEC) 60 654-1 and EN (IEC) 60 654-3.

Package is a box. Products in boxes is possible to load on the pallets (pallet is returnable). On the outer side of the package is stated:

- manufacturer label,
- name and type of product,
- number of pieces,
- other data – notices and stickers.

The forwarder is obliged to secure packed products, loaded on transportation means, against self-motion; if open transportation means are used, to secure their protection against atmospheric precipitations and splashing water. Displacement and securing of products in transportation means must provide their stable position, exclude the possibility of their inter-collision and their collision with the vehicle walls.

Transportation can be executed by heatless and non hermetic spaces of transportation vehicles with influences within the range:

- temperature: -25° C up to +70° C (a strange version – 45 ° C up to + 45 ° C)
- humidity : 5 up to 100 %, with max. water content 0.029 kg/kg of dry air
- barometric pressure 86 up to 108 kPa.

Upon receiving of EA examine, if during transportation, resp. storing did not come to its damage. At the same time verify, if the data on the labels corresponds to accompanying documentation and purchase-sale contract / order. Eventual discrepancies, faults and damages should be reported without any delay to supplier.



Electric actuators and their accessories must be stored in dry, well ventilated covered spaces, protected against impurities, dust, soil humidity (by placement to racks, or on pallets), chemicals and foreign interventions, at ambient temperature from -10°C up to +50°C and at relative air humidity max. 80 %.

It is not acceptable to store EA outdoors, or in areas not protected against direct climate influence!

Eventual damages to surface finish remove without delay – thus preventing damage by corrosion.

If storing takes longer than 1 year, it is necessary to inspect lubrication fillings before putting EA into operation and in case of need perform maintenance.

Assembled EA, but not put into operation is necessary to protect by the equivalent method as during storage (for example suitable protective cover).

After assembly to the armature in free and wet areas, or in areas with temperature changes, connect without delay heating resistor – thus preventing damages caused by corrosion from liquefied water in the control area.

Excessive preserving grease remove just before putting EA into operation.

1.11 Assessment of the product and packaging and removal of contamination

The product and its package are made of recycling materials. Do not throw the single parts of the package and of the product after their life but sort them according to instructions in corresponding executives or regulations of environment protection, and allow their recycling.

The product and its packing are not a source of any environment pollution or contamination and do not contain any dangerous waste.

2. Installation and dismantling of actuator

2.1 Installation



Abide by safety measures!

Note:

Repeatedly verify whether placing of EA corresponds to part "Operating conditions". If actual conditions differ from recommended, it is necessary to consult it with manufacturer.

Before starting of mounting the EA onto the valve:

- Check again whether the EA was not damaged during storing.
- Check whether the adjusted operation angle and connecting dimensions of the actuator (see the nameplate) are in compliance with the valve parameters.
- In case of inconsonance, perform adjusting according to the part Adjustment of actuator.

2.1.1 Mechanical connection electric actuator with valve

EA is by the producer adjusted to parameters according to the nameplate, with connecting dimensions according to the corresponding dimensional drawing and put it to a mid-position.

Before installation put the handwheel on.

Mechanical flange connection

- Properly defat contact surfaces of the EA, connecting flange and the valve/gearing.
- Coat the valve/gearing output shaft firmly with a grease not containing any acid.
- Reset the EA to the end limit position "closed"; put the valve to the same end limit position.
- Put the EA onto the valve to have the output shaft reliably in the valve/gearing coupling.
- Use the handwheel to turn the EA if needed to reach compliance between holes in the EA flange and the valve.
- Check whether the connecting flange clings to the valve/gearing.
- Fix the flange with four screws (with mechanical ruggedness min. 8G) tightened to allow moving of EA. Then the fixing screws tighten uniformly crosswisely.

Mechanical lever connection

- Clean contact surfaces of the stand and the base and coat the EA shaft and the pull-rods sliding surfaces with grease.
- Fix the EA to the device with two screws.
- Put the controlled device to the end limit position; put the EA with stop ends to the corresponding end limit position.
- Put the lever or another output element corresponding with the position as much as possible, in case that the position is not in compliance with required, tune it with the handwheel in range $\pm 15^\circ$.
- Connect the EA with the device with the pull-rod consisting of two ball pins and a 1/2" tube according to STN 42 5711 threaded on both ends.
- In EA without stop ends operation angle position can be adjusted with the handwheel, along the whole circumference without changing of setting of the lever.
- While installing take care to have the angle between the lever and the pull-rod at least 15° and at most 165° (Fig.3).

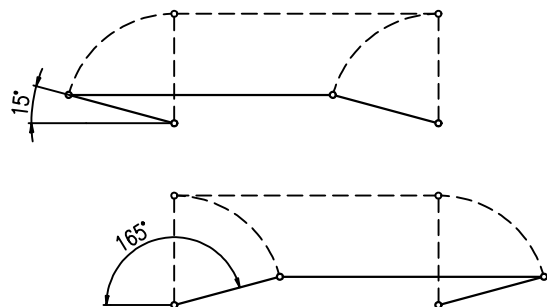

Fig.3

Notes:

1. Minimum mechanical ruggedness of screws is 8G.
2. If adjustment of the position-signalling unit, the transmitter or the position indicator in the production plant do not correspond with the EA connected this way, adjust the units. If adjustment of the stop ends was changed, it is needed to adjust the stop end screws again.

In the end of mechanical connection **check correctness of the connection with the valve/gearing** with rotating the handwheel.

2.1.2 Electric connection and checking of function

Follow up with connecting the EA with mains or master system.



1. Follow instructions in the part "Requirements for professional qualification"!
2. While laying electrical line abide by the instructions for heavy current installations. Power supply cables must be of the type approved. Minimum thermal resistance of power supply cables and wires must be +80°C.
3. Cables to terminal boards or connectors lead through screw cable gland.
4. Before initiation EA into operation internal and external protection terminals are needed to be connected.
5. Feeding cables are to be fixed to the solid construction at most 150 mm from the cable glands.
6. To prevent moisture from entering the actuator around the connecting cables, the cables must be sealed with silicone material at the point of penetration through device shell.

Connecting with the master system:

EA can be controlled by version:

- analogue signals through the built-in position controller
- binary inputs 24 V DC
- with Modbus communication protocol

EA is connected according to wiring diagram under the cover of EA.

Notes:

1. Wires of input control signals to controller and output signals from current converter it is necessary to lead them separately with thrust wires or it is necessary to use shielded wires.
2. The EA are delivered with cable glands, which in case of tight putting on the leads assure protection enclosure up to IP 68. For required protection enclosure it is needed to use rings according to the actual cable diameter.
3. While fixing the cable it is needed to count with allowed bend radius to avoid damaging or deformation of the sealing element of the cable gland. The leads are to be fixed with the solid construction at most 150 mm from the cable glands.
4. It is recommended to use screened cables to connect remote transmitters.
5. The face areas of the control part cover have to be before re-mounting clean, coated with grease without any acid (e.g. vaseline) and sealing not damaged to avoid joint corrosion.
6. Reversion of the EA is sure, if the period between switching-off and switching-on of power supply for the reversed movement of the output part is minimally 50 ms.



In version **SPR PA** it is necessary to do **calibration** in operation according by enclosure assure the optimal function.



Abide by instructions of valve producers, whether switching-off in end positions is to be realised with position or torque switches.

2.2 Dismantling



Before dismantling it is required to disconnect the EA from mains!
Do not connect and disconnect live connectors!

- Disconnect the EA from mains.
- Disconnect the leads from the EA terminal boards and loosen the cables from cable glands.
- Loosen the fixing screws of the EA flange and disconnect the EA from the valve/gearing.
- While sending the EA to be repaired put it into a package solid enough to avoid damages of the EA during transportation.

3. Adjusting of actuator



Attention! See chapter 1.2.3 Requirements on professional competence...

Observe safety regulations!

EA are delivered adjusted onto parameters according to type label from Production plant.

The adjustment can be performed at a mechanically and electrically connected EA. This chapter describes how to set up the ES to parameter values within a range applicable for the software. Laying of adjusters of the control board is shown on **Fig.6 and Fig. 6a**.

Adjusting is possible:

- by operating the control unit buttons (**see Fig. 6 and Fig. 6a**);
- by operating the local control panel buttons (**see Fig. 7**) – only for the EA s equipped with local control;
- through the programme once the EA is connected to the PC using the communication cable.

For the specific adjustment procedure or individual parameters reset see individual appendixes **74 1053 02 & 74 1076 02**.

For facilitating the simple setting of required operation parameters, the control unit is equipped with :

- four setting buttons: **MENU, P, O, C**
- six signal lamps according (LED diode) to **Fig. 6 and Fig. 6a**.

Status indication by means of LED diodes:

- **LED ERROR** (red) – blinks red in case of failure eventually lights in the parameter setting mode
- **LED OPEN / MENU** (green) – in the ON/OFF mode it lights with a control action for the **opening** direction eventually blinks with accessing the MENU mode
- **LED CLOSE / PAR** (red) – in the ON/OFF mode it lights with a control action for the **closing** direction eventually blinks besides the chosen parameter in the menu and lights up at writing the parameter into the memory
- **LED I1 / SEL** (yellow) – permanent lights with active input I1, or blinks in the mode of parameters set up.
- **LED I2** (yellow) – permanent lights with active input I2
- **LED POWER** (green) – it light on at leading the power supply

For version with Modbus communication

- LED DEX1 (yellow) – permanent lights during Modbus single Channel communication
- LED DEX2 (yellow) – permanent lights during Modbus duo Channel communication.

Electronics - programme selections option (by version)

- **relay R1; R2; RE1 to RE5**: disabled; open position; close position; torque-open; torque – close; torque open or torque close; torque open or position open; torque close or position close; open; close; movement; movement flasher; to position; from the position; warning; remote control; local control; control shut off.
- **relay READY**: errors, errors or warnings, errors or no remote, errors or warnings or no remote.
- **output signál** (from EPV passive): 4 to 20 mA; 20 to 4 mA.
- **control programme options** (regulating): 2P, 3P, 3P/2P I2
- **input control signal** (N): 0/4/12 to 20 mA, 4 to 12 mA, resp. 0/2 to 10 V.
- **input I1**: DISABLED; ESD; DBL (local releasing - not valid for this type of the EA), STOP
- **input I2**: DISABLED; ESD; DBL (local releasing - not valid for this type of the EA), 2P resp. E2P (for control programme option 3P/2P I2, *or in case of active communication through Modbus protocol*, allows control using the binary 24V DC inputs with I2 input activated).

- FAILURE REACTION: OPEN, CLOSE, STOP, SAFE POSITION

The identical functions cannot be set on I1 & I2 inputs in addition to the OFF state (e.g., if the ESD function is set on I1 input, it is not possible to select the ESD function on I2 input at the same time.

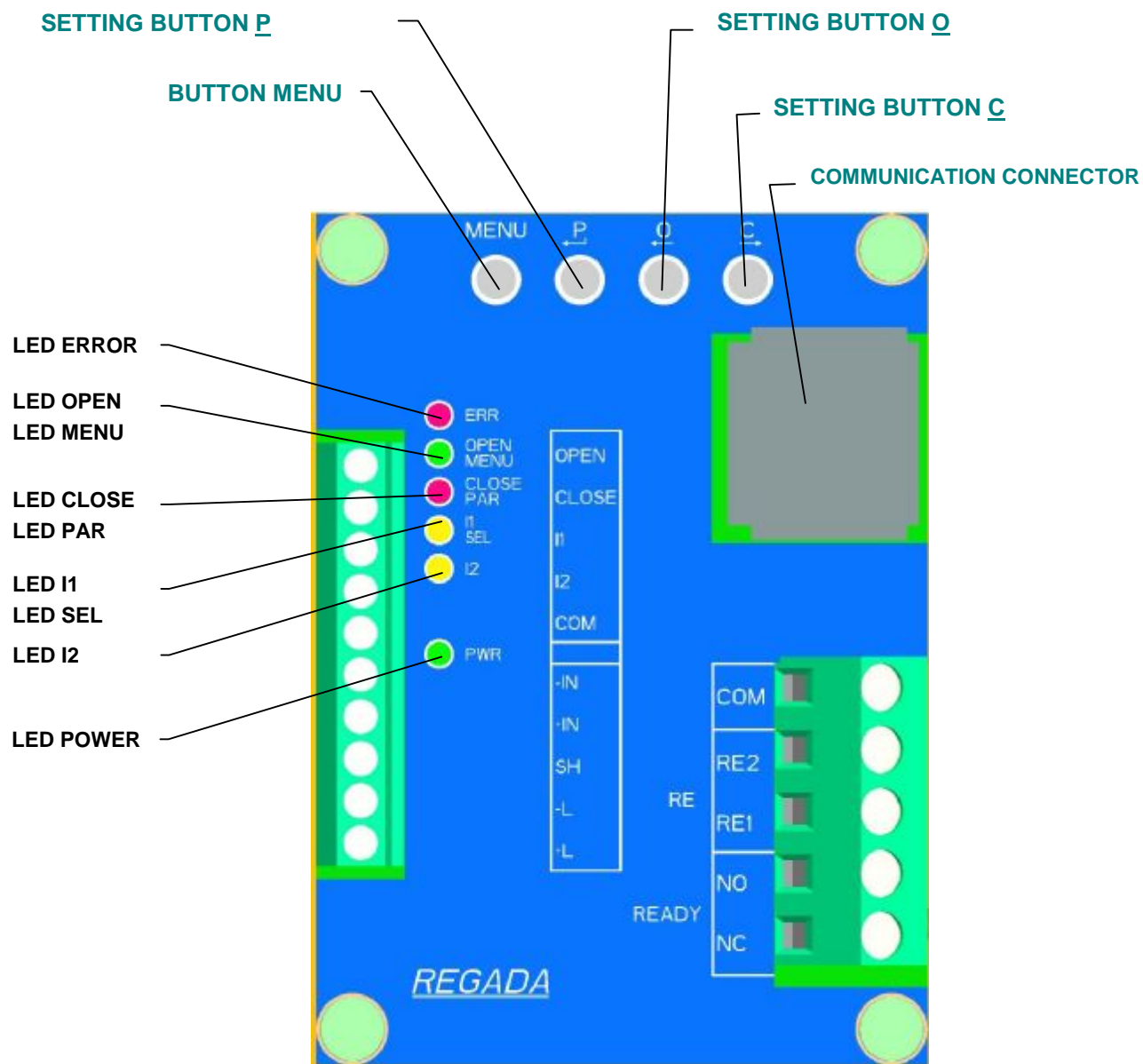

Fig. 6

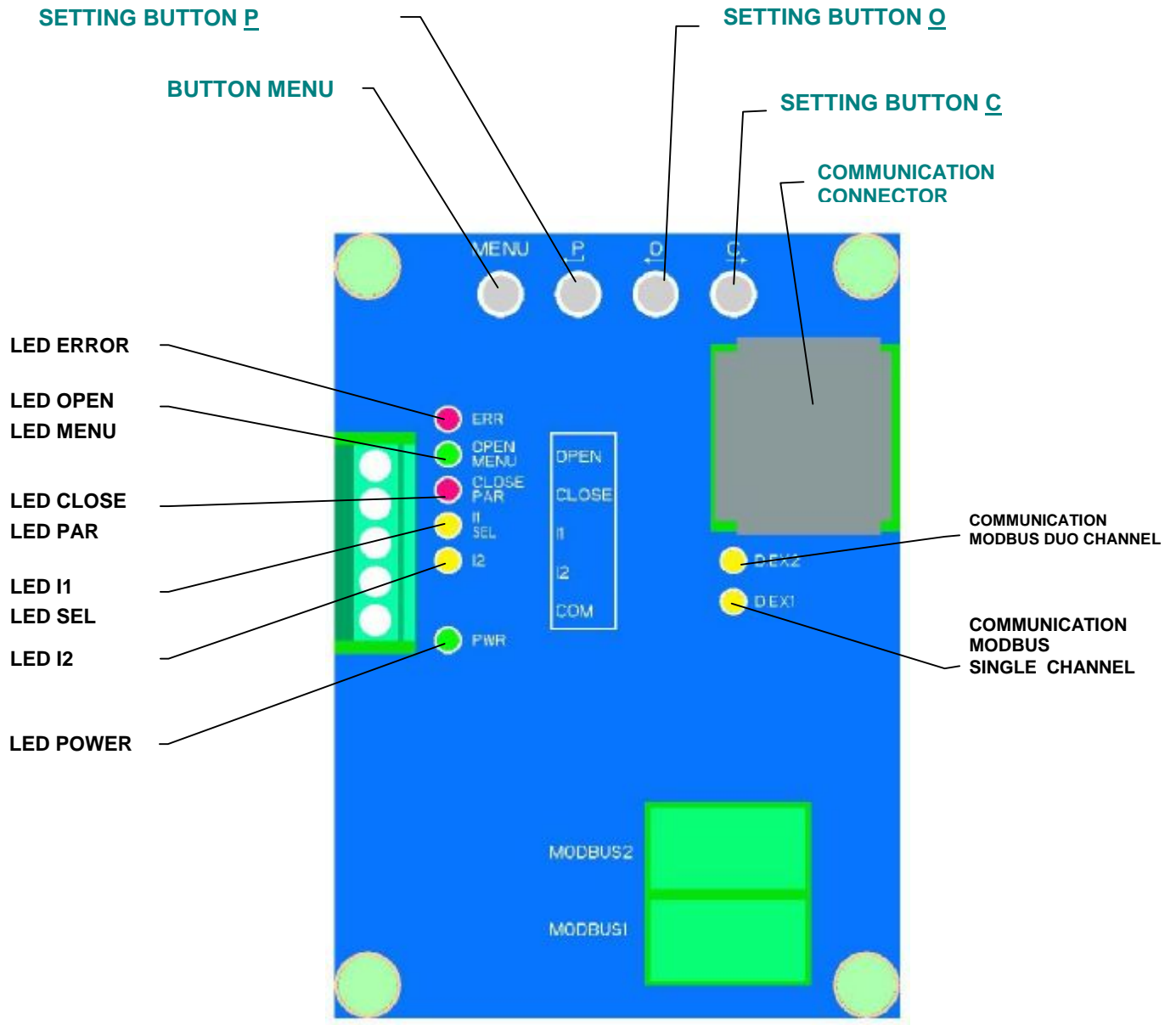

Fig.6a

3.1 EA control set-up options (regulating)

3.1.1 Control setting possibilities for EA's with DMS3 electronic control

2P CONTROL

Setting-up: 2P control + other functions, in addition to STOP on I1 outlet:

The EA moves either to the OPEN or CLOSE direction with 24V DC voltage supplied to terminals OPEN or CLOSE. The EA stops if power supply is cut-off or the end position is reached.

2P PULSE CONTROL

Setting-up: 2P control + STOP function on I1:

The EA moves either to the OPEN direction or closes with 24 V DC voltage pulse supplied on terminals OPEN or CLOSE. The EA stops – shutting off - once the 24 V DC voltages is supplied on I1 connector (STOP) or the set end position is reached.

3P CONTROL (REGULATING)

Setting-up: 3P control + other functions, in addition to STOP on I1 and other ones in addition to 2P on I2 input:

The EA moves either to the OPEN or CLOSE direction with 0/4/12 to 20 mA, 4 to 12 mA (0/2-10V) input control signal supplied on terminals +IN, -IN. The EA stops once the required position is reached (corresponding with the input control signal supplied) or the set end position is reached.

Note: The EA fails to stop in case that the STOP function is selected on I1 input with 3P control mode and 24V DC voltage supplied on I1 terminal.

3P/2P switched over to I2

Setting-up: 3P/2P control switched over to I2 (2P function is automatically selected for I2 input function in selecting this control option) + other functions in addition to STOP on I1:

The EA moves either to the OPEN or CLOSE direction with 0/4/12 to 20 mA, 4 to 12 mA (0/2-10V) input control signal supplied on terminals +IN, -IN. The EA stops once the required position is reached (corresponding with the input control signal supplied) or the set end position is reached.

The EA stops to respond to 0/4/12 to 20 mA, 4 to 12 mA (0/2 to 10 V) input control signal and rests in case of I2 active input (with 24V DC constantly ON or OFF – as per I2 function set-up to ACTIVE – or supplied on I2 connector). The EA is allowed to move either to the OPEN or CLOSE direction with 24V DC voltage supplied to terminals OPEN or CLOSE. The EA stops if power supply is cut-off or the end position is reached. The EA stops to respond to the input control signal and fixes its position once the supply voltage on I2 is OFF.

3P/2P switched over to I2 (PULSE 2P)

Setting-up: 3P/2P control switched over to I2 (2P function is automatically selected for I2 input function in selecting this control option) + other functions in addition to STOP on I1:

The EA moves either to the OPEN or CLOSE direction with input control signal 0/4 – 20 mA (0/4/12 to 20 mA, 4 to 12 mA (0/2-10V) supplied on connectors +IN, -IN. The EA stops once the required position is reached (corresponding with the input control signal supplied) or the set end position is reached.

The EA stops to respond to 0/4/12 to 20 mA, 4 to 12 mA (0/2-10V) input control signal and rests in case of I2 active input (with 24V DC constantly ON or OFF – as per I2 function set-up to ACTIVE – or supplied on I2 terminal). The EA is allowed to move either to the OPEN or CLOSE direction with 24 V DC voltage pulse supplied connectors OPEN or CLOSE. The EA stops once the 24V DC voltage is supplied on I1 terminal (STOP) or the set end position is reached.

The EA stops to respond to the input control signal and fixes its position once the supply voltage on I2 is OFF.

3.1.2 Control setting possibilities for EA's with DMS3 electronic control with MODBUS protocol

2P CONTROL (two position controller)

Setting: the two position controller is activated by setting the bit 3P=0 in the corresponding Modbus register:

The EA moves in the direction of open or closed **when the bits are set as OPEN, resp. CLOSE in the corresponding Modbus register.**

3P CONTROL (three position controller)

Setting: the three position controller is activated by setting the bit 3P=1 in the corresponding Modbus register:

The EA moves in the direction of open or closed **in accordance with the requirements sent through the Modbus interface.**

EMERGENCY CONTROL

Note: In cases where the EA is equipped with a local control, it is possible to activate the emergency control only if the local control block is set to remote control. The local control block has higher priority than the **ESD** or **E2P**.

- **ESD (Emergency Shutdown)** – is activated when the function parameter is set as **I1=ESD** and the I1 input is activated or when the function parameter is set as **I2=ESD** and the I2 input is activated. The EA takes up the position which corresponds to the settings of the **response to error parameter after input activation**. The **ESD emergency control has higher priority than the E2P control.**
- **E2P (Emergency 2P)** – is activated when the function parameter is set as **I2=E2P** and the I2 input is activated. The **E2P emergency control has lower priority than the ESD control.** Emergency 2P operates in two modes and uses the following inputs:
 - **Permanent signal** – the EA opens or closes only when a signal is present on the **OPEN, CLOSE inputs.**
 - **Impulse mode** – the EA opens or closes after supplying an impulse to the **OPEN, CLOSE inputs.** The EA is stopped after supplying an impulse to the **I1 input.** This mode is similar to the settings of the function **I1=STOP.**

3.2 Procedure for setting individual parameters and the register of errors and warnings

- is given in the separate attachment 74 1053 02 resp. 74 1076 02 of these operating instructions.

The factory default setting of individual programmes shown in Table 2 & 3, as long as otherwise specified by the customer:

Table 2
Factory default settings of individual parameters in version without local control; possibility to set-up by operating the control unite buttons.
 For the individual parameters set-up see appendix 74 1053 02

| MENU | | NAME | FACTORY SETTING-UP | |
|------|--------|---|--|------------------------|
| DMS3 | MODBUS | | | |
| 1 | | TORQUE | 100% of value shown on nameplate for OPEN & CLOSE direction. | |
| 2 | | END LIMIT | - C = Position + O = Position - end position switching closed and open from position if valve type is not specified - C = Torque + O = Position - closed in end by thrust position and end position switching open from position for single-seat valves - C = Torque + O = Torque – switching in both end positions by thrust for double-seat valves | |
| 3 | | TORQUE BLOCKING | - 2 sec. blocking time - 5% blocking position for OPEN & CLOSE direction | |
| 4 | | RELAY READY | - errors (READY COM-NO relay contacts closed in error free conditions) | |
| 5 | | RELAY R1..RE5 | - position O for relay R1 - position C for relay R2 - from position 95% for relay RE3 - To position 5% for relay RE4 -disabled for RE5 relay | |
| 6 | - | CPT (output signal) | 4 to 20 mA | |
| 7 | - | REGULATION – (according to specification) | 2P | 3P |
| | | ANALOG INPUT | - | 4 to 20 mA (2 to 10 V) |
| - | 6 | ADDRESS | 2 | |
| - | 7 | BAUDRATE PARITY REDUNDANCY | 115200 bit/s EVEN OFF (for single Channel version) COMPONENT (for duo Channel version) | |
| 8 | | DEAD ZONE | - | 3 % |
| 9 | | FAILURE REACTION | STOP | |

Other parameters set-up not possible to change using the PC software

| TITLE | FACTORY SETTING-UP |
|------------------------|------------------------------------|
| THERMOSTAT TEMPERATURE | 25 °(space heater OFF temperature) |
| INTERNAL DEAD ZONE | 2 % (only for 3P) |
| Safe position | 0 % |
| FUNCTION I1 | ESD |
| ACTIVE I1 | high level |
| FUNCTION I2 | DISABLED |
| ACTIVE I2 | high level |
| THERMAL FUSE FAILURE | functionless with this EA type |
| THERMAL FUSE RESET | functionless with this EA type |
| CYCLE MODE | DISABLED |
| CYCLE RUNNING TIME | 10 s |
| CYCLE PAUSE | 50 s |

| | |
|-----------------------|-----------|
| CYCLE POSITION O1 | 0 % |
| CYCLE POSITION O2 | 100 % |
| CYCLE POSITION C1 | 0 % |
| CYCLE POSITION C2 | 100 % |
| O AND C TOLERANCE | 1 % |
| CREATE BACKUP | START |
| RESTORE FROM BACKUP | START |
| RESTORE FACTORY SETUP | START |
| ACTIVE ERRORS | CLEAR |
| DIRECTION OF ROTATION | clockwise |
| REDUNDANCY | OFF |
| CONNECT TIME | 3s |

Table 3

Factory default settings of individual parameters in version with local control; possibility to set-up by operating the local control buttons. For the individual parameters set-up see appendix 74 1076 02.

| MENU | | NAME | FACTORY SETTING-UP | |
|------|--------|---|--|------------------------|
| DMS3 | MODBUS | | | |
| 1 | | JAZ/LANGUAGE | English (select language on LCD display) | |
| 2 | | POSITION O | work angle range set as per EA specification | |
| 3 | | POSITION C | | |
| 4 | | REG. CALIBR. | START | |
| 5 | | END LIMIT | C = Position, O = Position - end position switching | |
| 6 | | TORQUE O | 100% of value shown on nameplate | |
| 7 | | TORQUE C | 100% of value shown on nameplate | |
| 8 | | BLOCK. TIME | 2 s | |
| 9 | | BLOCK. POS. O | 5 % | |
| 10 | | BLOCK. POS. C | 5 % | |
| 11 | - | CPT (output signal) | 4 to 20 mA | |
| 12 | - | REGULATION-(according to specification) | 2P | 3P |
| 13 | - | ANALOG. INPUT | - | 4 to 20 mA (2 to 10 V) |
| 14 | 16 | DEAD ZONE | - | 3 % |
| 15 | 17 | INT. DEAD Z. | - | 2 % |
| 16 | 18 | FAIL. REACT. | STOP | |
| 17 | 19 | SAFE POSIT. | 0 % | |
| 18 | 20 | FUNCTION I1 | ESD | |
| 19 | 21 | ACTIVE I1 | high level | |
| 20 | 22 | FUNCTION I2 | DISABLED | |
| 21 | 23 | ACTIVE I2 | high level | |
| 22 | 24 | THERMO. FAIL. (THERMAL FUSE FAIL) | functionless with this EA type | |
| 23 | 25 | THERMO. RESET (THERMAL FUSE | functionless with this EA type | |
| 24 | 26 | RELAY READY | errors | |
| 25 | 27 | RELAY 1 | Position O (POSITION OPEN) | |
| 26 | 28 | RELAY 1 POS. | 0 % | |
| 27 | 29 | RELAY 2 | Position C (POSITION CLOSE) | |
| 28 | 30 | RELAY 2 POS. | 0 % | |
| 29 | 31 | RELAY 3 | FROM POSITION | |
| 30 | 32 | RELAY 3 POS. | 95 % | |
| 31 | 33 | RELAY 4 | TO POSITION | |
| 32 | 34 | RELAY 4 POS. | 5 % | |
| 33 | 35 | RELAY 5 | DISABLED (OFF) | |
| 34 | 36 | RELAY 5 POS. | 0 % | |

| | | | |
|----|----|---------------|--|
| 35 | 37 | CYCLE MODE | DISABLED |
| 36 | 38 | CYCLE RUN. T. | 10 s |
| 37 | 39 | CYCLE PAUSE | 50 s |
| 38 | 40 | OC TOLERANCE | 1 % |
| 39 | 41 | INFORMATION | TORQUE |
| 40 | 42 | RESTORE BACK. | START |
| 41 | 43 | CREATE BACK. | START |
| 42 | 44 | RESTORE FACT. | START |
| 43 | 45 | ACTIVE ERR: | CLEAR |
| - | 11 | ADDRESS | 2 |
| - | 12 | BAUDRATE | 115200bit/s |
| - | 13 | PARITY | EVEN |
| - | 14 | REDUNDANCY | OFF (for single Channel version) COMPONENT (for duo Channel version) |
| - | 15 | CONNECT TIME | 3s |

Other parameters set-up is possible to change only by using the PC software

| NAME | FACTORY SETTING-UP |
|------------------------|------------------------------------|
| DIRECTION OF ROTATION | clockwise |
| THERMOSTAT TEMPERATURE | 25 °(space heater OFF temperature) |
| CYCLE POSITION O1 | 0 % |
| CYCLE POSITION O2 | 100 % |
| CYCLE POSITION C1 | 0 % |
| CYCLE POSITION C2 | 100 % |
| LCD CONTRAST | 0 |

Warning 1: When the input control signal is set to the value 0 , 20 mA (0 to 10 V), or 20 , 0 mA (10 to 0 V) and the input control signal fails, then the EA keeps the position as with a 0 mA (0 V) input signal (EA doesn't recognise between input signal fail and 0 mA (0 V) input signal) - not his does not apply to EA´s equipped with a Modbus/Profibus protocol.

Warning 2: Calibration process doesn't run if triggered in time when the EA is overloaded (EA is switched off from overloading - i.e. one of the power switches S1 or S2 is switched on). In such case, the EA must be moved in a position in which no one of the S1 and S2 power switches is switched on, and to start the calibration again.

Warning 3: Calibration process must be performed at any change of the operating angle value of more than 10%.

Warning 4: Operate adjusting button P on the control to activate the calibration process or start it from MENU 4 in the version with local control (use the buttons on local control) or from the programme once the EA is connected to the PC. All calibration start methods have been equal.

Warning 5: In case that EA with supply voltage 3x400V AC after calibration start shows the error „rotation direction“ (error No. 7), it is necessary to stop EA by switching-off the supply voltage and change the phases sequence on the terminals 2 and 3 (change mutually phases wires) and after switching-on the supply voltage run n the calibration agai.

Rotation direction definition of the electric actuator´s output element

Electric actuator is set by the producer in the following way: while looking at the output shaft of the actuator from the upper cover side, the output shaft moving in the direction “Close“ is rotating clockwise. It means that the direction of rotation of the actuator is set as clockwise

In case the direction of rotation shall be changed the parameter „Direction of rotation of the actuator“ must je adjusted as anticlockwise. This parameter can be adjusted through the PC only by use of the EHL Explorer SW. The PC must be connected to the actuator via communication cable and the window “Parameters“ used for direction adjustment.

3.3 **Putting an EA into operation when the EA is set up and connected with the armature already in the production plant (starting the calibration)**

If EA is delivered from manufacturing plant joined with valve, or with control device, **calibration** must be performed to ensure correct operation, under actual pipeline conditions.

The procedure is as follows:

- fit the given assembly into the specified technology complex
- connect the EA on the supply voltage electrically according to the wiring diagram and chapter Electrical connection....
- introduce the EA into an half-position (see Note 2 presented above)
- switch on the supply voltage
- start the EA calibration by pressing the **P** button on the control unit **for 2 seconds as minimum** until LED ERROR (red), LED MENU (green) and LED PAR (red) light up – see also the procedure in the separate attachment No.74 1053 02
- release the **P setting button**
- after releasing the **P** button the calibration procedure starts – inertia measuring
- after the calibration procedure is finished, the EA is prepared for its operation and starts to response to control inputs
- if changes to some parameters would be necessary, proceed please according to the instructions given in the separate attachment No. 74 1053 02.

3.4 **Putting an EA into operation when the parameter setting done by the producer suit to your needs**

When an EA is delivered from the producer without armature and the setting of stroke (stroke end positions) and other parameters done by the producer suit Your needs, please proceed as follows:

- connect the EA with the armature to be controlled (**according to chapter 2**) and fit this assembly into the specified technology complex
- connect the EA electrically according to the wiring diagram and chapter Electrical connection ...
- introduce the EA into an half- position (see Note 2 presented above)
- switch on the supply voltage
- start the EA calibration by pressing the **P** button on the control unit **for 2 seconds as minimum** until LED ERROR (red), LED MENU (green) and LED PAR (red) light up – see also the procedure in the separate attachment No. 74 1053 02
- release the **P setting button**
- after releasing the **P** button the calibration procedure starts
- after the calibration procedure is finished, the EA is prepared for its operation and starts to response to control inputs
- if changes to some parameters would be necessary, proceed please according to the instructions given in the separate attachment No. 74 1053 02.

3.5 **Putting an EA into operation when it is necessary to do a change to the angle (setting new end positions), and the other parameter setting done by the producer suits to your needs**

When an EA is delivered from the producer without armature, and the setting of other parameters done by the producer suit to your needs, and it is necessary to do a change to the EA stroke, proceed as follows:

- connect the EA with the armature to be controlled (according to chapter 2) and fit this assembly into the specified technology complex,
- connect the EA electrically according to the wiring diagram and chapter Electrical connection... ,turn on the power supply, without connection of the control signals fed into EA (The EA will report an error i.e. alarm No. 2 or No. 27 (missing input control signal - or Modbus activity),
- set the EA (*using manual control**) to end position **closed** and push button **C** **for at least 2s**, until LED ERROR (red), LED MENU (green) and LED PAR (red) come on – the **closed** end position is thus recorded in memory – see description in separate annex **No. 74 1053 02**,
- release the **C setting button**,
- set the EA (*using manual control**) to end position **opened** and push button **O** **for at least 2s**, until LED ERROR (red), LED MENU (green) and LED PAR (red) come on – the **opened** end position is thus recorded in memory – see description in separate annex **No. 74 1053 02**,
- **release** the **O setting button**,
- **introduce** the EA into an intermediate position (see Note 2 presented above),

- by pressing the **P** pushbutton on the control unit **for at least 2s** activate the EA calibration until LED ERROR (red), LED MENU (green) and LED PAR (red) come on – see also description of the procedure in separate annex **No. 74 1053 02**,
- release the adjustment pushbutton **P** - upon release of the **P** pushbutton, the calibration process is started,
- turn on the control signals, EA is ready for operation and responds to control inputs,
- if any of the parameters need to be changed, proceed according to the instructions in separate annex **No. 74 1053 02**.

* *This* This applies to setting of EA to be controlled by 2P and 3P or 3P/2P switched by I1, at the same time with standard setting of menu 9 FAILURE REACTION: STOP!

If the input control signal is set to one of the ranges starting from 0 mA, it is necessary to change the range to a different one. If this is not the case and a control signal is not supplied, the servodrive output component will take up the position corresponding to 0 mA. After recording the new limit positions change the value of the input control signal and response to error to the required parameters.

Note: *in cases where the sequence is implemented using a PC in the EHL Explorer programme or using local control, neither the change of response to error nor disconnection of the control signals is required.*

3.6 Setting other parameters

If changes to some parameters would be necessary, proceed please according to the instructions given in the separate attachment No 74 1053 02.

3.7 Error messages from the control unit

The EA electronics makes possible to identify some failures of EA. The failure is signalled by flickering LED ERROR (red) on the control unit (Fig.6). An error has also been indicated on the LED display. An error is indicated on the LCD display in the local control EA version.

The list of errors and warnings and the way for identifying a given error as well are presented in the separate attachment No. 74 1053 02. For identifying the reason of the error, the EA can be connected to a PC and the program helps you find the type of the error.

The list of errors and warnings compiled by the producer is presented in table 4 (chapter 4.3).

The list of errors and warnings and the way for identifying a given error as well are presented in the separate attachment No 74 1053 02.

A field serviceman is only entitled to change the errors and warnings set using the programme once the EA is connected to the PC.

3.8 Resetting of operation angle and setting of stop end screws

The valve operation angle position is defined with the stop end screws which allow to change the position from the position "Z" (closed - 0°) and from the position "O" (open - 60°, 90°, 120°, 160°) by a value of $\pm 15^\circ$, see **Fig.8**. The stop end screws serve as mechanical limits of the operation angle position at manual control or as end travel points for torque switching-off, else the mechanical gearing could be damaged. Therefore the output stop end may not to hit them when the EA is motor operated without having the torque unit set up. Otherwise the mechanical transmission could become damaged.

Note:

The stop end screws allow to extend or to reduce the operation angle by 30° in the adjusted EA, but output shaft position cannot be tuned. Also the position unit is to be adjusted to this angle and the transmitter has to be out of mesh.

3.8.1 Setting of stop end screws at position-unit switching-off

EA is equipped by torque disconnection, which provides the emergency function against overloading in the case that EA does not disconnected. We must ensure by adjusting of backstop bolts for EA shut off from the position so that disconnection from the reason of torque does not happen sooner than the disconnection from position (swell up to stop end).

The procedure is as follows:

- Loosen the counter-nut of the stop end screw "Z".
- Rotate the stop end screw to right until you feel an increased resistance while touching the end. From this status turn the screw min. by 1/2 of revolution back to avoid torque switching.
- Lock the screw with the counter-nut.
- Use similar steps to set the stop end screw for the position "O".
- Set up particular combination of EA shut off in the end limit positions and run calibration in the MENU 2 for EA shut off in the end positions

3.8.2 Setting of stop end screws at torque switching-off

In case the stop ends screws function as end points (stop ends) of the EA output shaft travel the EA torque unit is to be adjusted not to have the switching-off torque exceeded.

We must ensure by set up of backstop bolts for EA disconnection from the torque, so disconnection from position in the end position would not happen sooner than disconnection from the torque (swell up to stop end).

The procedure is as follows:

- Put the EA with the handwheel to the position "Z" (closed).
- Loosen the counter-nut of the stop end screw "Z".
- Rotate the stop end screw to right until you feel an increased resistance while touching the end - lock the screw with the counter-nut.
- Use similar steps to set the stop end screw for the position "O".
- Adjust the position-signalling unit to switch-off before torque switching-off.
- Set up particular combination of EA shut off in the end positions and run calibration in the MENU 2 for EA shut off in the end limit positions

| Type | A | B | C | D | S |
|-----------|----|------|------|-----|----|
| SPR 1PA | 26 | 13 | 11 | M8 | 13 |
| SPR 2PA | 46 | 18,5 | 16 | M10 | 16 |
| SPR 2.3PA | 34 | 12,5 | 10 | M12 | 19 |
| SPR 2.4PA | 44 | 15,5 | 12,5 | M14 | 22 |

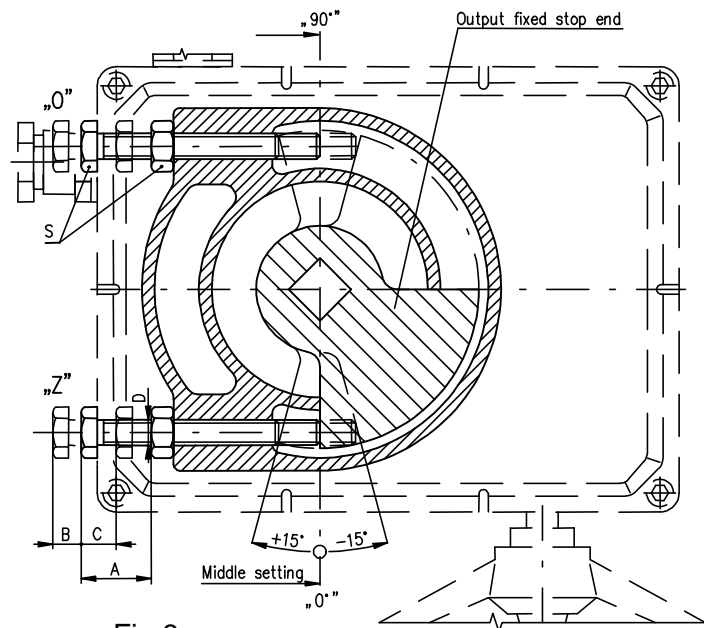

Fig.8

4. Service, maintenance and troubleshooting

4.1 Service



1. In general it is provided that service of the EA is performed by a qualified worker in accordance with requirement given in Chapter 1!
2. After putting the EA into operation it is needed to verify whether during manipulation any scratch on surface occurred, it is to be removed to prevent actuator against corrosion!

- The EA SPR PA requires just negligible service. Proper putting into operation is a precondition of reliable operation.
- The service of the EA leads from the operation conditions and usually resides in information processing for further arranging of required functions. The EA can either undergo electric remote control or manual control from the installation site. Operate the hand wheel for manual control.
- The stuff has to perform prescribed maintenance to prevent the EA during operation against impacts of environment, which exceed the frame of allowed influences.

At a power outage or voltage breaking off, an electric actuator will stop in a position, in which it had been before the power outage occurred. In case of need it is possible to preset the electric actuator with manual operation .

Manual control:

If needed (during adjusting, function checking, failure etc.) the stuff can change setting of the controlled body using the handwheel. While rotating the handwheel clockwise the output part moves in the direction "closed".

Electric local control: - additional equipment (Fig.7)

If necessary in the case of accession, function check and so on, it is possible to preset EA or change some parameters by local electric control with secured power feeding.

It is possible to control after removing of the padlock (1). Control mode selection is changed by sequential pressing of the button (2) **REMOTE-OFF-LOCAL** to "Remote" "Shut off", "Local", "Shut off", which is displayed on 2 rows LCD (6). Signalling motion and failure of the EA is also indicated by LEDs diode (7).

Mode "Shut off" – it is possible to change some parameters in this mode in particular menus.

Mode "Local" – it is possible to control EA by the local buttons in this mode - (3) **OPEN**, (5) **STOP**, (4) **CLOSE**.

Mode "REMOTE" – it is possible to control EA by the commands from superior remote system

Proceeding in setup of particular parameters in the mode "**SHUT OFF**" is described in the independent amendment No. 74 1076 02, which is delivered together with EA equipped by local electric control.

When you finish the work in the "REMOTE" mode put the padlock on the button (2) again. This measure would be received because of potential unauthorized person's intervention.

Note: Modes of Local or Remote control is conditioned by program choices of inputs I1 and I2. In the case that inputs I1 or I2 are programmed for "Local releasing", it is only possible to control the EA by local control with active input I1 or I2.

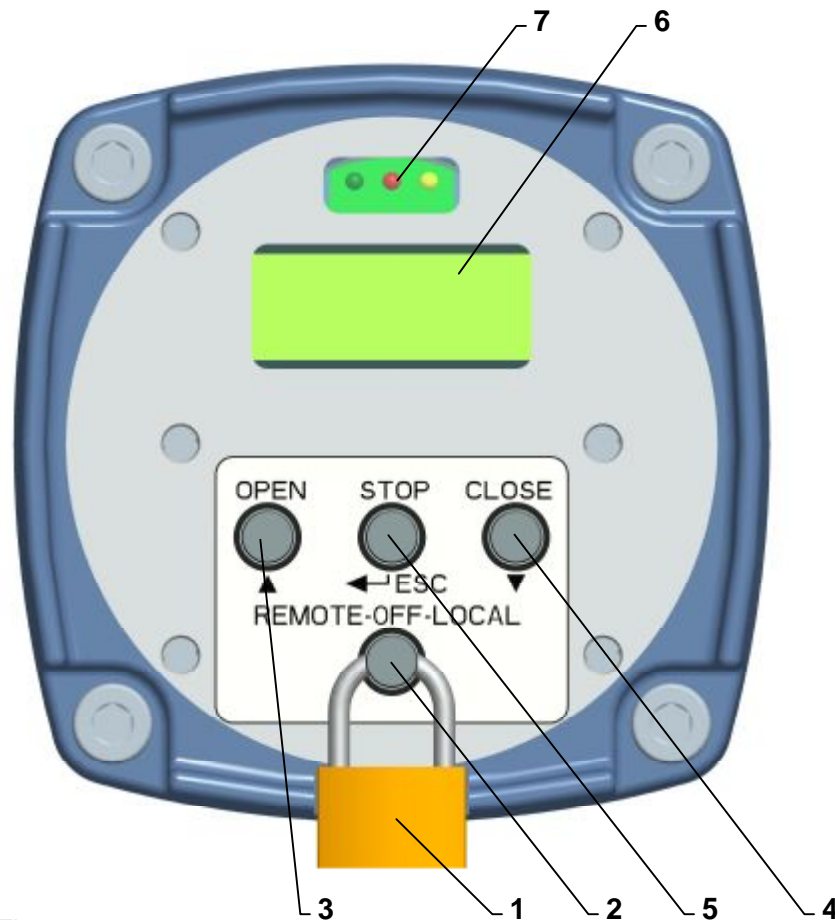

Fig. 7

4.2 Maintenance - extent and periodicity

During inspections and maintenance is needed to tighten all screws and nuts that affect the tightness and coverage. Similarly, once a year should be checked and if necessary tighten mounting screws of the terminal wires and assuring of the slip-on joints with wires.

The interval between two preventive inspections is four years.

The replacement of cover gaskets and gasket of an oil filling is needed in case of damage or after 6 years of the operation.

The grease in the supplied actuators is designed for the lifetime of the product. It is not necessary to change the grease during the operation of the actuator.

Lubrication:

- gear part - in versions for climate with temperatures -25°C till $+55^{\circ}\text{C}$ – grease HF 401/0 (GLEIT- μ) resp. GLEITMO 585 K
- in versions for climate with temperatures -40°C till $+40^{\circ}\text{C}$ grease ISOFLEX TOPAS AK 50.



Lubrication of the valve stem is independent on maintenance of the EA!

After every potential flooding of the product check, whether there is no water inside. After eventual water penetration, dry the product before repeated putting into operation and replace damaged sealings, resp. other parts of EA. identically check also tightness of cable bushings and replace them, if they are damaged.

Every six months it is recommended to perform one check move in frame of adjusted operation stroke to verify reliability of functioning with setting back to the original position.

If the audit rules do not determine else the inspection of EA is performed ones a year and tightening of all connecting and grounded screws have to be checked to avoid overheating.

After 6 months from putting of EA into operation and once a year it is recommended to check tightening of fixing screws between the EA and the valve. (Tighten the screws with the cross system.)



While connecting and disconnecting of the EA check the tightness of cable glands – those with damaged sealings should be replaced by new ones of the approved type!
 Keep the EA clean and take care about removing impurities and dust. The cleaning has to be performed regularly according to the operation possibilities and requirements.

4.3 Troubleshooting

At failure of power supply the EA stops in the position where it was before the failure. If needed the EA can be set only with the manual control (the handwheel). After restoration of power the EA is prepared for operation.

In case of failure of any element of the EA it can be changed by a new one. Entrust the change to a service centre.

In case of an EA failure, which cannot be eliminated directly in operation, follow instructions for under-guaranty and after-guaranty service.

Note: If the EA requires dismantling follow the chapter "Dismantling".

The EA electronics makes possible to identify some failures of the electric actuator. The control unit blinking LED ERROR indicates the failure (**Fig. 6**) or the error is displayed on the LED (**see Fig. 1**), or the LCD display (**see Fig. 7**). The list of errors and warnings and the way for identifying a given error as well are presented in the separate attachment No 74 1053 02.

The list of errors and warnings compiled by the producer is presented in **table 4**. A change to the list of errors and warnings in the EA is only possible within a service intervention, through the program installed in a PC.

| Table 4 setting error flags and warning flags as at the delivery | | |
|---|-------|---------|
| PARAMETER | ERROR | WARNING |
| ESD | | X |
| Analog Input – not valid for Modbus version | | X |
| Modbus activity – only for Modbus version | | X |
| Wrong command | X | |
| Torque | | X |
| Torque check | | X |
| Torque calibration | X | |
| Regulator calibration | | X |
| Stroke (turns sum) | X | |
| Wrong position | X | |
| Spin | X | |
| Spin direction | X | |
| RAM | X | |
| ROM | X | |
| EEPROM | | X |
| Bus | X | |
| I2C | X | |
| Reset | | X |
| Voltage +5V | | X |
| Parameters | X | |
| Set mode | | X |
| Relay | | X |
| Temperature < | | X |
| Temperature > | | X |
| Phase | X | |
| Power frequency | X | |
| Thermal fuse | X | |
| Manual control | X | |
| Position module | X | |
| Position module type | X | |
| Position sensor 1 | X | |
| Position sensor 2 | X | |
| Position sensor 3 | X | |
| Position sensor 4 | X | |
| Torque module | X | |
| Torque module type | X | |

| | | |
|--------------------------------|---|--|
| Torque sensor | X | |
| LED module | X | |
| LED module type | X | |
| LCD module | X | |
| LCD module type | X | |
| Power Supply/Relay module | X | |
| Power Supply/Relay module type | X | |

Notes: **X** – the error or warning flag is activated.
 With the **error flag**, the EA takes the position defined for the FAILURE REACTION function eventually stops (depending on the kind of the error), and it will not operate until the error is removed.
 With the **warning flag**, the EA continues in operation.
 The user is advised on error or warning through the READY relay (according to the relay setting), eventually through the program after connecting the EA with a PC.

Note 1: In some cases having the error removed the electric actuator must be restarted by switching-off the voltage supply to the electric actuator for about 3 sec.

For repairing eventually the electronics use the fuse – see Fig.2 (F3) for example SHURTER MSF 250, or a sub miniature SIBA 164050 xxx (see chapter 1.9.2), which is located on source board. For three - phase EA versions with contactless switching (SSR), fuses are installed in a fuse housing, see Fig. 2e (F4-1, F4-2), such as SIBA 7012540.xxx with a value in accordance with section 1.9.2 on electronic system holders.

Note:

If the EA requires dismantling follow the chapter "Dismantling".



Taking the EA to pieces for repair purposes is allowed only by professionally qualified persons trained in the production plant or by a contracted service centre!

5. Accessories and spare parts

5.1 Accessories

The EA is delivered with the **handwheel and cable glands**.

5.2 Spare part list

Table 5 Spare part

| Spare part | Order Nr. | Position | Figure |
|--|------------|----------|--------|
| Electric motor; 4W/25 VA; 230/220 V AC; 50 Hz | 63 592 309 | 1 | 1 |
| Electric motor; 4W/25 VA; 24 V AC; 50 Hz | 63 592 357 | 1 | 1 |
| Electric motor; 5W/28 VA; 24 V AC; 60 Hz | 63 592 064 | 1 | 1 |
| Electric motor; 5W/28 VA; 240 V AC; 60 Hz | 63 592 062 | 1 | 1 |
| Electric motor; 5W/28 VA; 120 V AC; 60 Hz | 63 592 063 | 1 | 1 |
| Electric motor; 15W/39 VA; 230/220 V AC; 50 Hz | 63 592 314 | 1 | 1 |
| Electric motor; 15W/39 VA; 24 V AC; 50 Hz | 63 592 356 | 1 | 1 |
| Electric motor; 15W; 3x400/3x380 V AC; 50 Hz | 63 592 332 | 1 | 1 |
| Electric motor; 18W/48 VA; 24 V AC; 60 Hz | 63 592 061 | 1 | 1 |
| Electric motor; 18W/48 VA; 240 V AC; 60 Hz | 63 592 059 | 1 | 1 |
| Electric motor; 18W/48 VA; 120 V AC; 60 Hz | 63 592 060 | 1 | 1 |
| Electric motor; 20W/75 VA; 230/220 V AC; 50 Hz | 63 592 118 | 1 | 1A |
| Electric motor; 25W/70 VA; 240 V AC; 60 Hz | 63 592 057 | 1 | 1A |
| Electric motor; 25W/70 VA; 120 V AC; 60 Hz | 63 592 058 | 1 | 1A |
| Electric motor; 60W/120 VA; 230/220 V AC; 50 Hz | 63 592 323 | 1 | 1A |
| Electric motor; 70W/125 VA; 240 V AC; 60 Hz | 63 592 055 | 1 | 1A |
| Electric motor; 70W/125 VA; 120 V AC; 60 Hz | 63 592 056 | 1 | 1A |
| Electric motor; 90W; 3x400/3x380V AC | 63 592 328 | 1 | 1A |
| | | | |
| DMS3 Z2 24A source board of electronic for 24 V AC | 64 051 072 | 3 | 1, 1A |
| DMS3 ZS switch – mode power supply for 230 V AC and 115 V | 64 051 103 | 3 | 1, 1A |
| | | | |
| | | | |
| Position scanning unit DMS3 SP | 64 051 079 | 4 | 1,1A |
| Torque scanning unit DMS3 ST | 64 051 080 | 6 | 1,1A |
| | | | |
| Control unit of the electronics DMS3 J1 (0/4/12 to 20 mA, resp.4 to 12 mA) | 64 051 075 | 2 | 1,1A |
| Control unit of the electronics DMS3 J3 (0/2 to 10 V) | 64 051 061 | 2 | 1, 1A |
| Control unit of the electronics DMS3 J2 (without input and output) | 64 051 060 | 2 | 1, 1A |
| Control unit of the electronics MODBUS single Channel | 64 051 051 | 2 | 1, 1A |
| DMS3 L2 LED display | 64 051 081 | 7 | 1,1A |
| DMS3 LCD display | 64 051 082 | 6 | 7 |
| DMS3 H3.4 local control sensor | 64 051 084 | - | 7 |
| DMS3 RE3 Module of additional relays | 64 051 065 | 8 | 1 |
| DMS3 RE6 Module of additional relays | 64 051 066 | 8 | 1 |

6. Enclosures

6.1 Wiring diagrams EA SPR PA – for single - phase supply

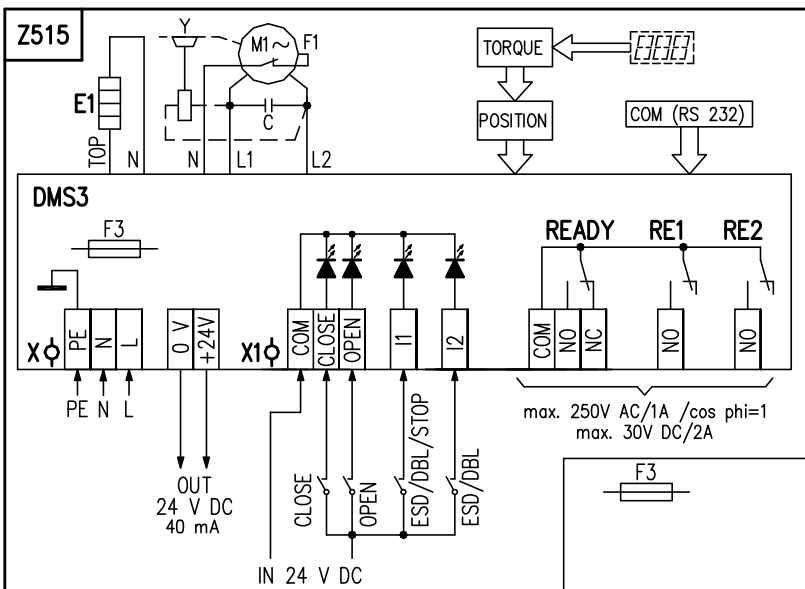
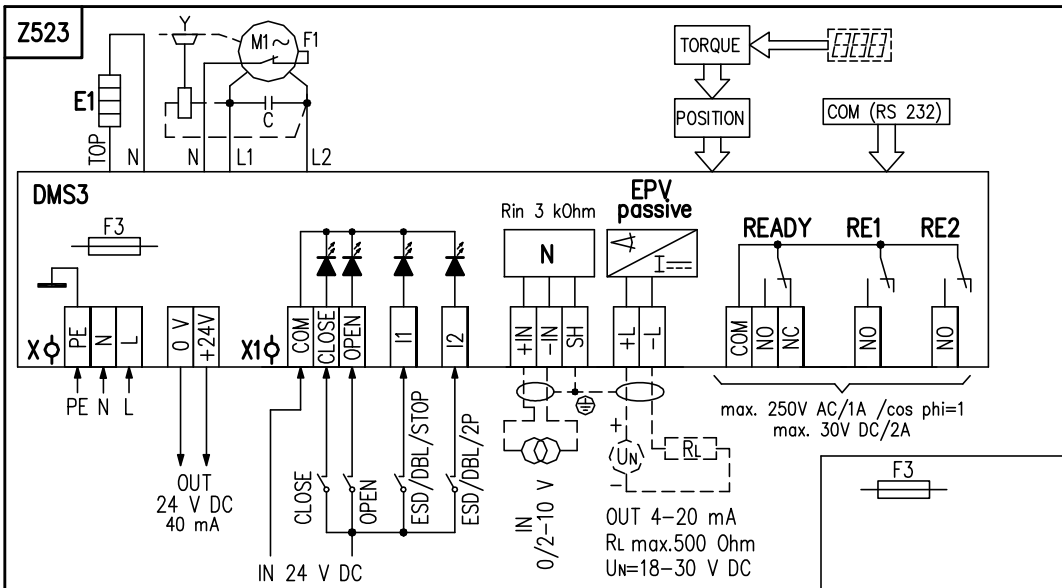
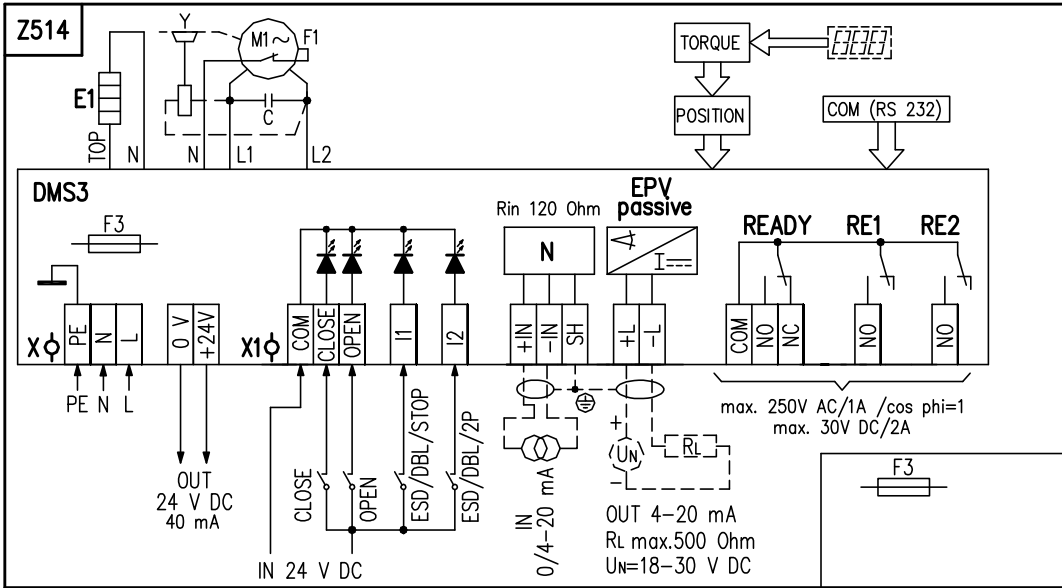

6.2 Wiring diagrams EA SPR 1PA – for three - phase supply

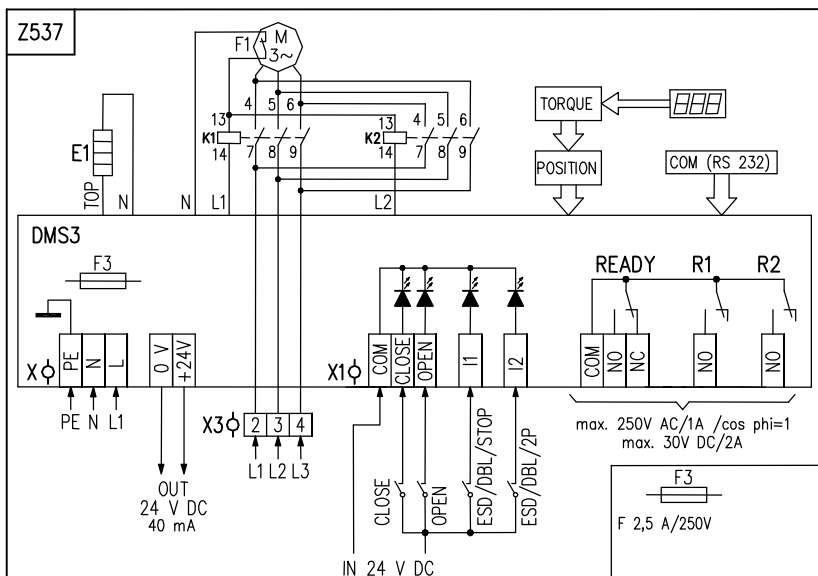
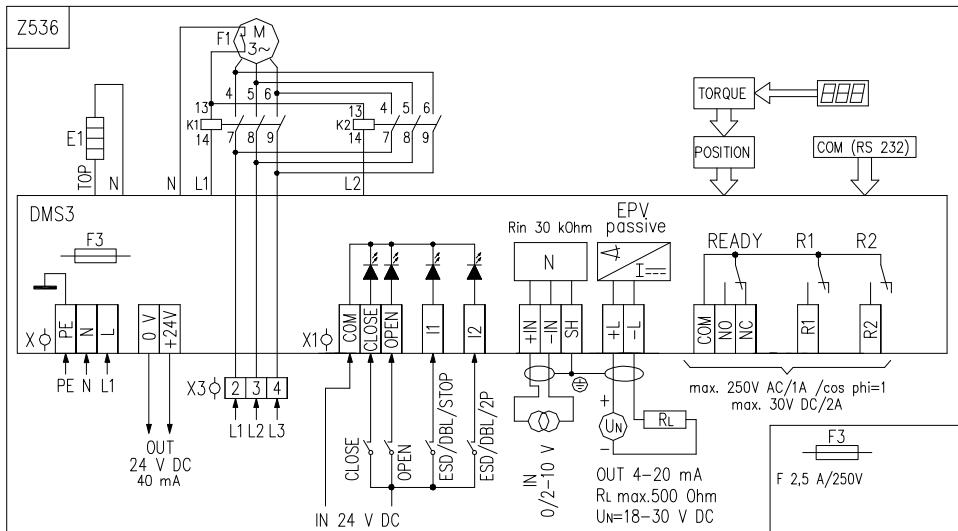
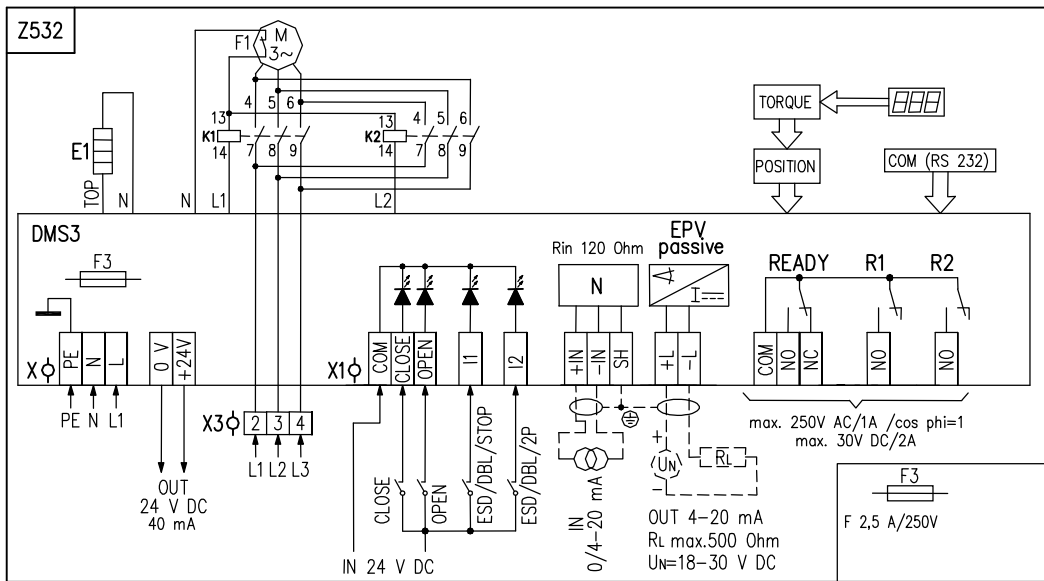

6.3 Wiring diagrams EA SPR 2PA, SPR 2.3PA, SPR 2.4PA – for three - phase supply

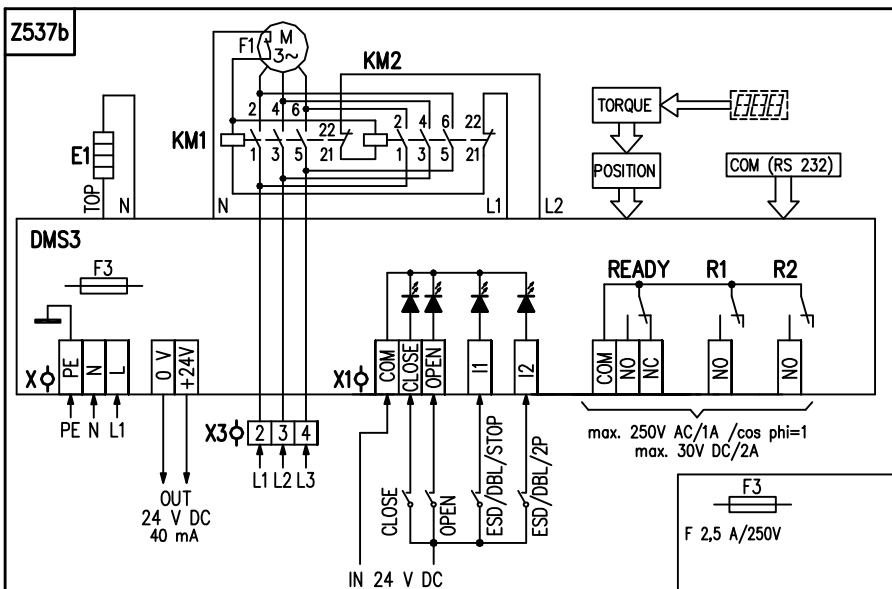
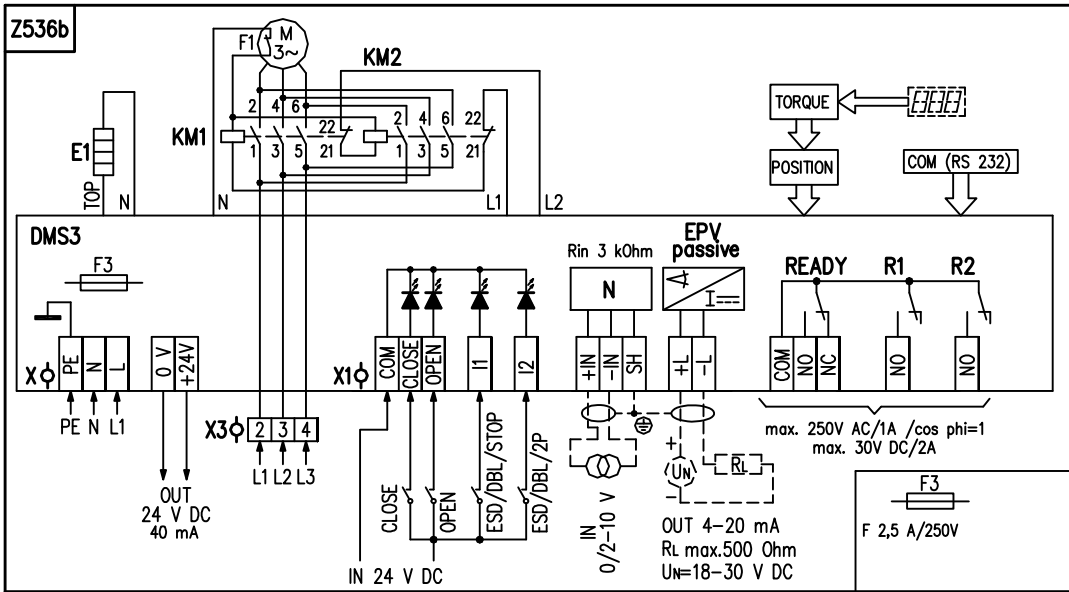
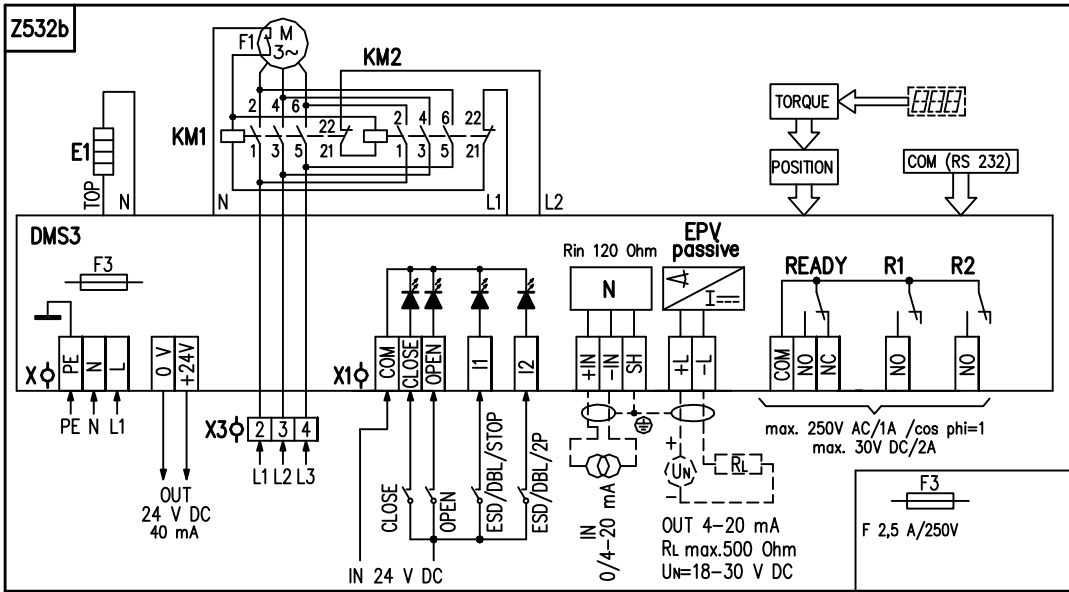

6.4 Wiring diagrams EA SPR PA – for three - phase supply without reverse unit

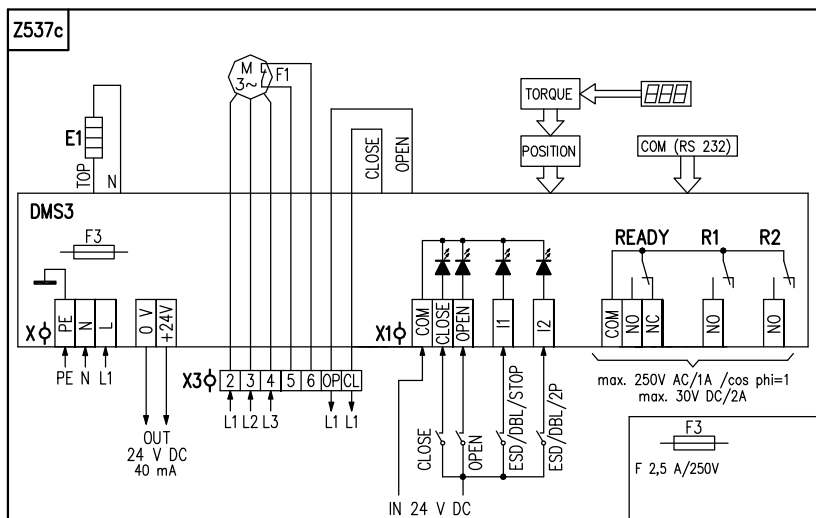
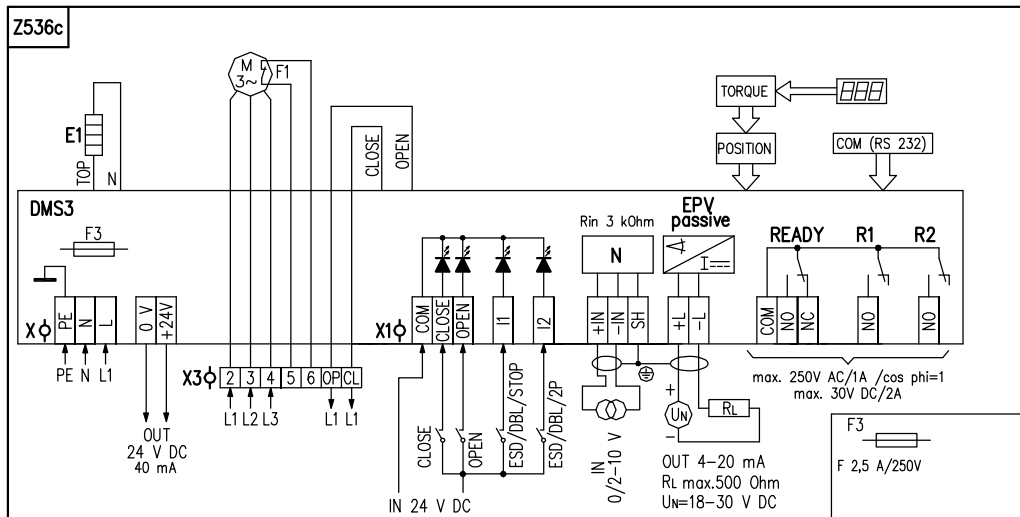
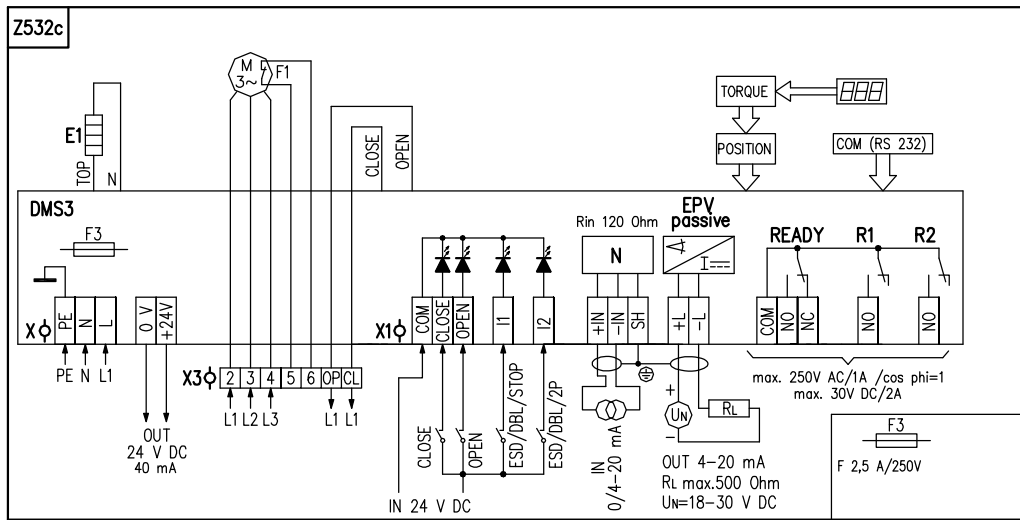

6.5 Wiring diagrams ES SPR PA – for three phase supply with-contactless switching

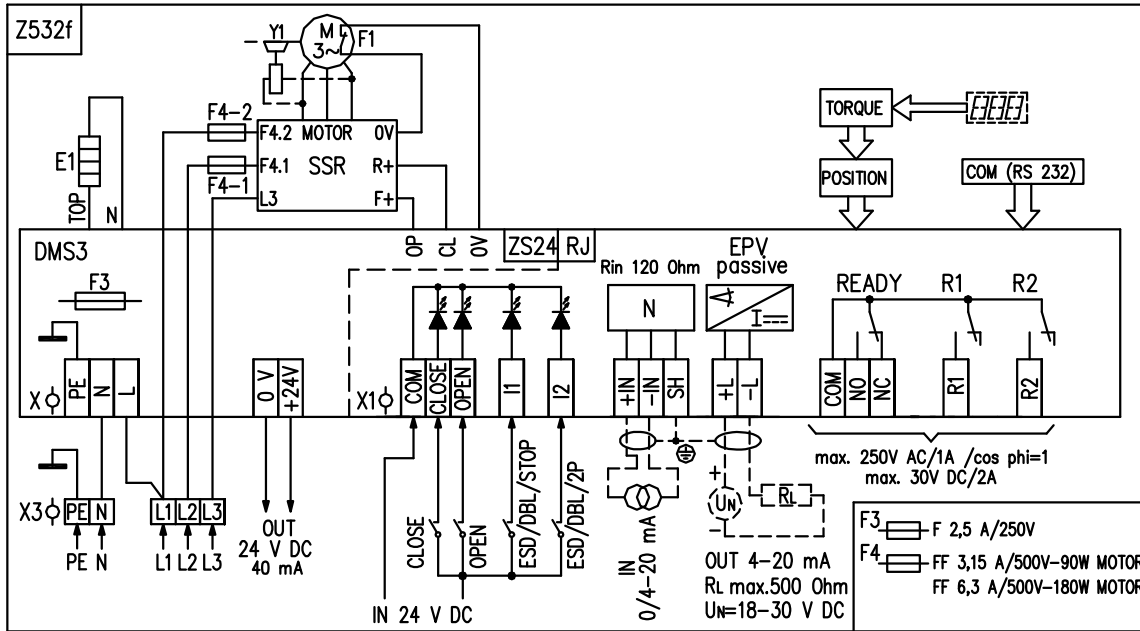

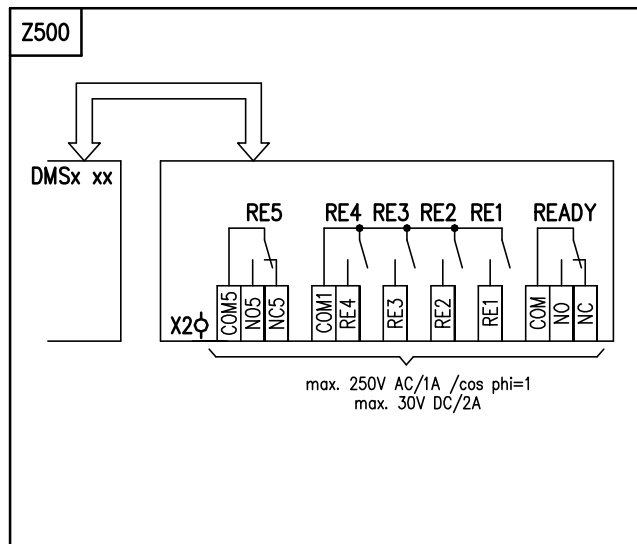
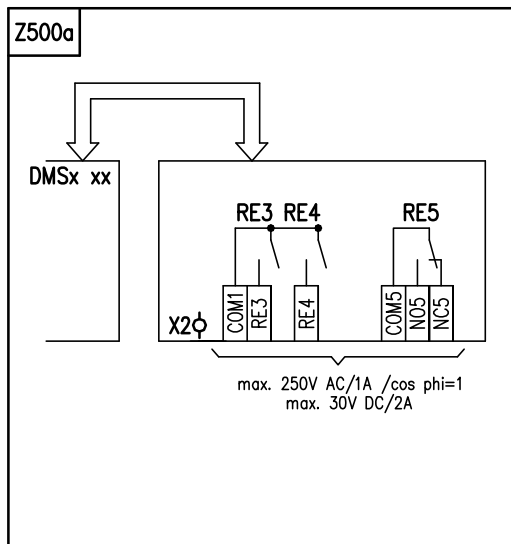
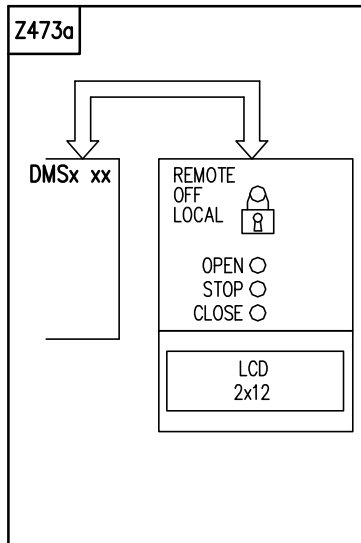

6.6 Wiring diagrams EA SPR 2PA, SPR 2.3PA, SPR 2.4PA with interface Modbus/Profibus - three - phase supply

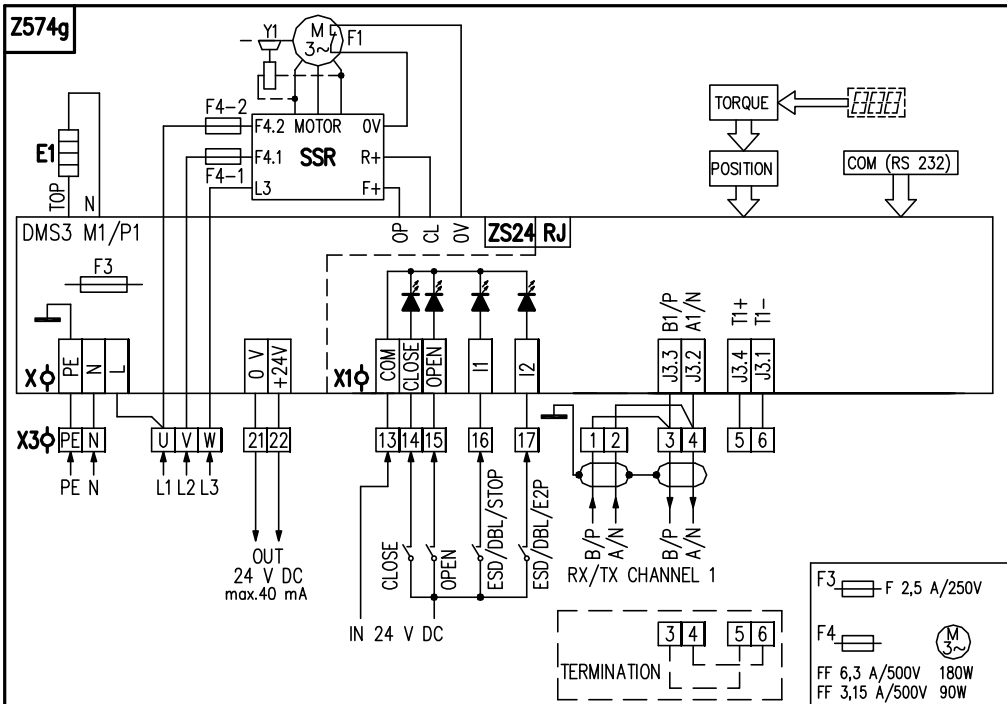
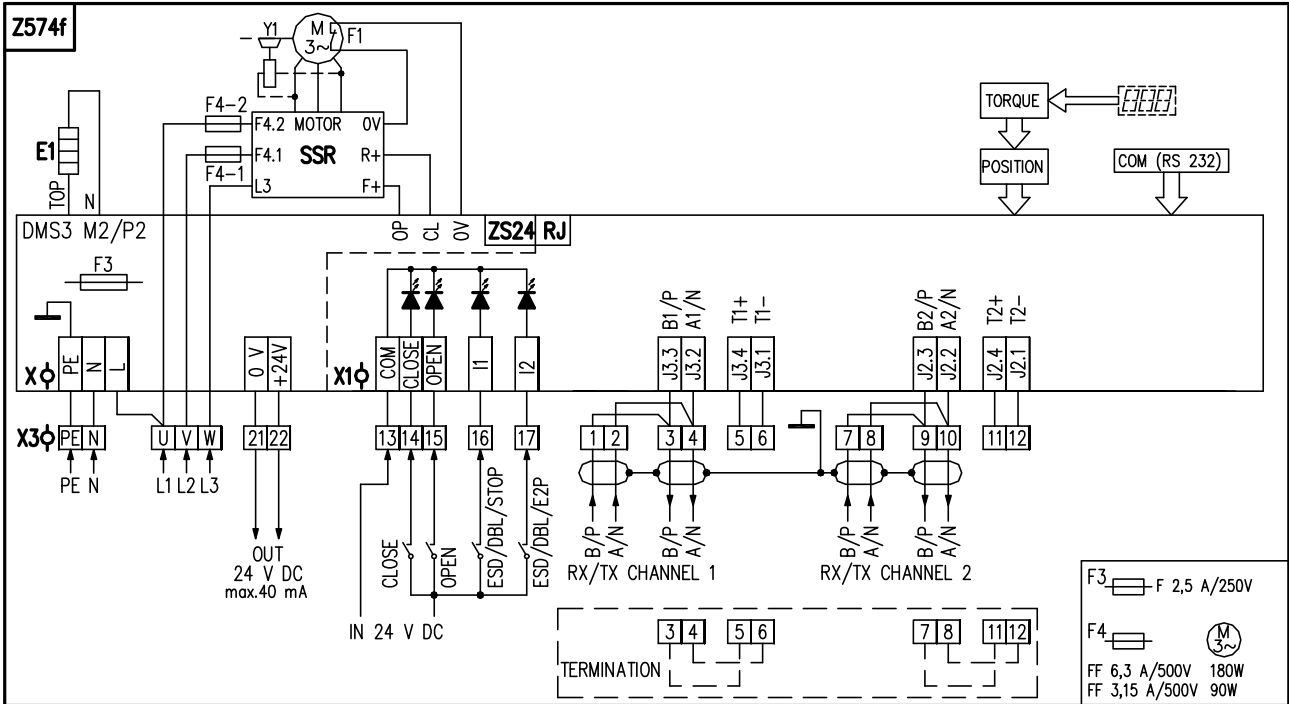

Legend:

- Z473a wiring diagram of electric local control
- Z500 wiring diagram module with 6 additional relays
- Z500a wiring diagram module with 3 additional relays
- Z514 wiring diagram of EA SPR 1PA, SPR 2PA, SPR 2.3PA, SPR 2.4PA for the ON/OFF control resp. for analogue input and output signal
- Z515 wiring diagram of EA SPR 1PA, SPR 2PA, SPR 2.3PA, SPR 2.4PA for the ON/OFF control
- Z523 wiring diagram of EA SPR 1PA, SPR 2PA, SPR 2.3PA, SPR 2.4PA for the ON/OFF control or resp. for analogue input signal 0/2 to 10 V and output signal 4 to 20 mA
- Z532 wiring diagram of EA SPR 1PA with three - phase electric motor for the ON/OFF control or for analogue input 0/4/12 to 20 mA, 4 to 12 mA and output signal 4 - 20 mA
- Z536 wiring diagram of EA SPR 1PA with three - phase electric motor for the ON/OFF control or for analogue input 0/2 - 10 V and output signal 4 - 20 mA
- Z537 wiring diagram of EA SPR 1PA with three - phase electric motor for the ON/OFF control
- Z532b wiring diagram of EA SPR 2PA – SPR 2.4PA with three - phase electric motor with contactors for the ON/OFF control or for analogue input 0/4/12 to 20 mA, 4 to 12 mA and output signal 4 - 20 mA
- Z532c wiring diagram of EA SPR PA with three - phase electric motor without reverse unit for the ON/OFF control or for analogue input 0/4/12 to 20 mA, 4 to 12 mA and output signal 4 - 20 mA
- Z536b wiring diagram of SPR 2PA – SPR 2.4PA with three - phase electric motor with contactors for the ON/OFF control or for analogue input 0/2 - 10 V and output signal 4 - 20 mA
- Z536c wiring diagram of SPR PA with three - phase electric motor without reverse unit for the ON/OFF control or for analogue input 0/2 - 10 V and output signal 4 - 20 mA
- Z537b wiring diagram of EA SPR 2PA with three - phase electric motor with contactors for the ON/OFF control
- Z537c wiring diagram of EA SPR PA with three - phase electric motor without reverse unit for the ON/OFF control
- Z574f wiring diagram of EA SPR 2PA – SPR 2.4PA with interface Modbus/Profibus, duo Channel version with three - phase supply with contactless switching
- Z574g wiring diagram of EA SPR 2PA – SPR 2.4PA with interface Modbus/Profibus single Channel version with three - phase supply with contactless switching
- Z532f wiring diagram of EA STR 2PA with 3-phase electric motor – contactless switching.

- C capacitor
- COM(RS232) possibility for connecting the control unit to a PC
- EPV passive electronic position transmitter is passive with output current signal
- E1 space heater
- F1 motor`s thermal protection
- F3 fuse of voltage supply source
- M single - phase electric motor
- N controller
- POSITION position scanning
- R_{in} input resistance
- R_L load resistance
- U_N voltage for EPV
- READY READY relay (free-programmable)
- R1 to RE5 additional relays
- SSR reversing module contactless switching of three - phase electric motor

- TORQUE torque scanning
- DMS3 electronic module
- DMS3 M1/P1 electronic module with interface Modbus/Profibus single Channel version
- DMS3 M2/P2 electronic module with interface Modbus/Profibus duo Channel version

- X voltage supply source terminal board with screw terminals
- X1 terminal board with screw terminals on the control unit
- X2 screw terminal box on the additional relays board
- X3 screw, resp. terminal boards with spring connection (for Modbus version)

Terminals:

PE, N, L – terminals (0,05-1,5 mm²) of supply (24 V AC resp. 110/120 V AC, resp. 230/240 V AC, 50/60 Hz (according to the specification))

2, 3, 4 – terminals (max. 1,5 mm²) of supply three - phase motor 3x400 resp. 3x380 V AC

5,6 – terminals (max. 1,5 mm²) of three - phase motor`s thermal protection for version without reverse unit for version without a Modbus/Profibus protocol)

1,2,3,4,5,6 – terminals with spring connection (0,08 – 2,5 mm²) of single Channel interface Modbus/Profibus

7,8,9,10,11,12 - terminals with spring connection (0,08 – 2,5 mm²) of redundant interface Modbus/Profibus

PE,N,U,V,W - terminals with spring connection (0,08 – 2,5 mm²) of power supply of electronic 230 V AC and three - phase electric motor 3x400 V AC.

OP, CL – terminals (max. 1,5 mm²) of output of control for without reverse unit

0 V, +24 V – terminals (max. 1,5 mm²) of output voltage 24 V DC (40 mA)

21,22 - terminals with spring connection (0,08 – 2,5 mm²) of output voltage 24 V DC (40 mA)

COM, CLOSE OPEN, I1, I2 – terminals (0,05 - 1 mm²) of control inputs 24 V /DC

13,14,15,16,17- terminals with spring connection (0,08 – 2,5 mm²) of control inputs 24 V DC

+IN, -IN, SH – terminals (0,05 - 1 mm²) of analogue input current and voltage signal

+L, -L, SH – terminals (0,05 - 1 mm²) of output current signal (passive) 4-20 mA

COM, NO, NC, NO, NO – terminals (0,05 - 1,5 mm²) of relay READY, relay R1 and R2 (on control unit)

COM5, NO5, NC5 – terminals (0,05 – 1,5 mm²) relay RE5 (on the module of the additional relays)

COM1, RE4, RE3, RE2, RE1 – terminals (0,05 - 1,5 mm²) relay RE4, RE3, RE2, RE1 (on the module of the additional relays)

COM, NO, NC – terminals (0,05 – 1,5 mm²) of relay READY (on the module of the additional relays)

Note 1:

On terminal N, L terminal power supply (X) feed supply voltage 230 V AC, or 24 V AC by you - specified type of construction EA. For supply voltage 24 V AC no need connect ground wire PE. For a version of EA with the supply voltage 3x400 or 3x380V, terminals N, L on terminal board of power supply (X) are fed by power supply 220 respectively 230 V AC.

Note 2:

Program possibilities for **R1, R2, RE1, RE2, RE3, RE4, RE5** relays: **DISABLED**, open position, close position, torque-open, torque – close, torque open or torque close, torque open or position open, torque close or position close, open, close, movement, movement flasher, to position, from position, warning, remote control, local control, control shut off.

Program possibilities for **READY** relay: errors, errors or warnings, errors or no remote, errors or warnings or no remote.

Program possibilities for output signal (from **EPV** passive): 4 to 20 mA, 20 to 4 mA.

Control programme options (regulating)(**this does not apply to EA`s equipped with a Modbus protocol**): 2P, 3P, 3P/2P switched over to I2

Program possibilities for **input control signal (N)**: 4 to 20 mA, (2 to 10 V), 20 to 4 mA, (10 to 2 V), 0 to 20 mA, (0 to 10 V), 20 to 0 mA. (10 to 0 V), 4 to 12 mA, 12 to 4 mA, 12 to 20 mA, 20 to 12 mA

- Program possibilities for setting Modbus communication protocol:

address – 1 to 247

baudrate [bit/s] – 1200, 2400, 4800, 9600, 19200, 38400, 57600, 115200

parity – even, odd, none

redundancy –off, cabel, component, repeater

connect time [s] – 0,1 to 25,5s

Program possibilities **for inputs I1: DISABLED**, ESD, DBL (local releasing, remote releasing), STOP.

Program possibilities **for inputs I2: DISABLED**, ESD, DBL (local releasing, remote releasing), STOP

2P, resp. E2P (when controller is switch on)(for control programme option 3P/2P I2, resp. for active communication through Modbus protocol) allows control using the binary 24V DC inputs with I2 input activated.

Program possibilities of FAILURE REACTION ESD: OPEN, CLOSE, STOP, SAFE POSITION.

The identical functions cannot be set on I1 & I2 inputs in addition to the disabled state (e.g., if the SAFE function is set on I1 input, it is not possible to select the ESD function on I2 input at the same time.

Relay READY on the control unit is doubled with relay READY on the power supply board.

Relay R1 and relay R2 on the control unit is doubled with relay RE1 and relay RE2 on the power supply board.

6.7 Dimensional drawings

Dimensional drawings – flanged type

P-1147 Flange ISO 5211

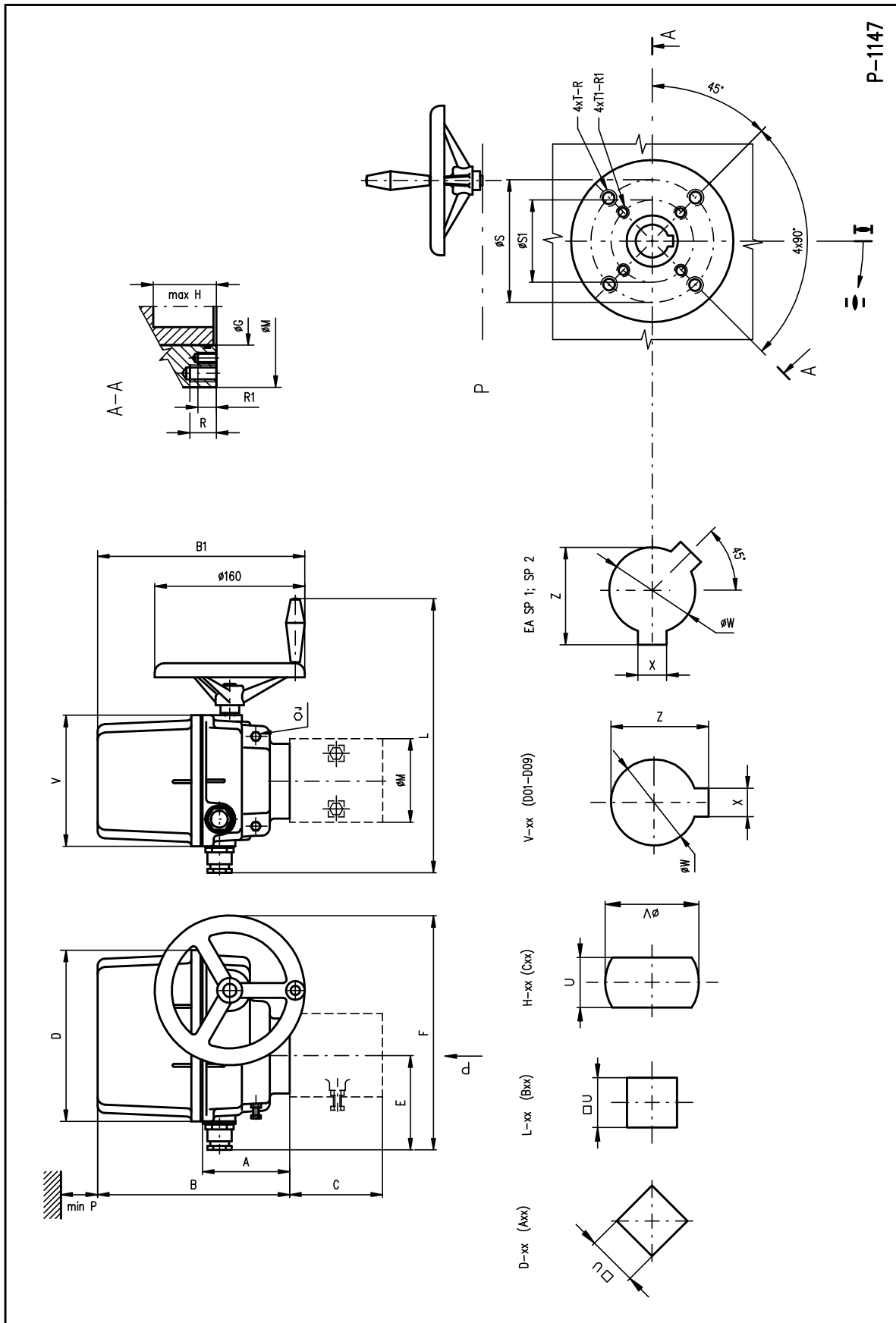

P-1147

| FLANGE DIMENSIONS | | | | | | | | | |
|-------------------|----|----|----|----|-----|-----|-----|-----|-------------|
| Typ | G | H | R | R1 | S | S1 | T | T1 | Flange size |
| SPR 1PA | 40 | 32 | 16 | 12 | 70 | 50 | M8 | M6 | F07/F05 |
| SPR 2PA | 40 | 37 | 16 | 12 | 70 | 50 | M8 | M6 | F07/F05 |
| SPR 2.3PA | 55 | 56 | 20 | 16 | 102 | 70 | M10 | M8 | F10/F07 |
| SPR 2.4PA | 65 | 71 | 24 | 20 | 125 | 102 | M12 | M10 | F12/F10 |

| Type | A | B | B1 | C | D | E | E1 | F | F1 | F2 | J | L | M | P | V |
|-----------|-----|-----|-----|-----|-----|-------------|-----|-------------|-----|-------------|----|-------------|-----|-----|-----|
| SPR 1PA | 102 | 213 | 229 | - | 183 | 98 170* | 169 | 248 320* | 319 | 273 345* | 13 | 276 290* | 90 | 160 | 140 |
| SPR 2PA | | | | - | | | | | | | 17 | | 90 | | |
| SPR 2.3PA | 104 | 260 | 267 | 112 | 232 | 123 203* | 194 | 297 377* | 368 | - | 19 | 326 351* | 125 | 210 | 190 |
| SPR 2.4PA | | | | 127 | | | | | | | 22 | | 150 | | |

Note: * - These dimensions are valid for versions with connector.

Coupling shapes

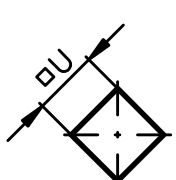
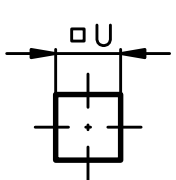
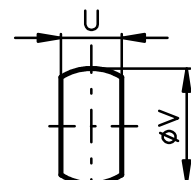
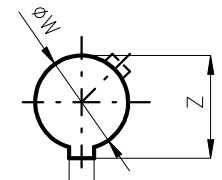
| Shape D | | Shape L | | | Shape H | | Shape V | | | |
|---|----|---|----|------|---|----|---|------|------|------|
|  | |  | | |  | |  | | | |
| D-xx | U | L-xx | U | H-xx | U | V | V-xx | W | Z | X |
| D-14 | 14 | L-14 | 14 | H-14 | 14 | 22 | V-20 | 20,0 | 22,5 | 6,0 |
| D-17 | 17 | L-17 | 17 | H-11 | 11 | 18 | V-22 | 22,0 | 24,5 | 6,0 |
| D-22 | 22 | L-22 | 22 | H-8 | 8 | 13 | V-32,2 | 32,2 | 35 | 6,5 |
| D-27 | 27 | L-27 | 27 | H-17 | 17 | 25 | V-17 | 17,0 | 19,5 | 6,0 |
| D-11 | 11 | L-11 | 11 | H-13 | 13 | 19 | V-28 | 28,0 | 30,9 | 8,0 |
| D-16 | 16 | L-16 | 16 | H-22 | 22 | 32 | V-42 | 42,0 | 45,1 | 12,0 |
| | | | | H-16 | 16 | 22 | V-45,4 | 45,4 | 48,8 | 10,0 |
| | | | | H-27 | 27 | 48 | V-50 | 50,0 | 53,5 | 14,0 |
| | | | | H-19 | 19 | 28 | V-18 | 18,0 | 20,5 | 6,0 |
| | | | | H-10 | 10 | 16 | V-30 | 30 | 32,5 | 8 |

P-2032 Version EA with local control
 (others parameters – see P-1147)

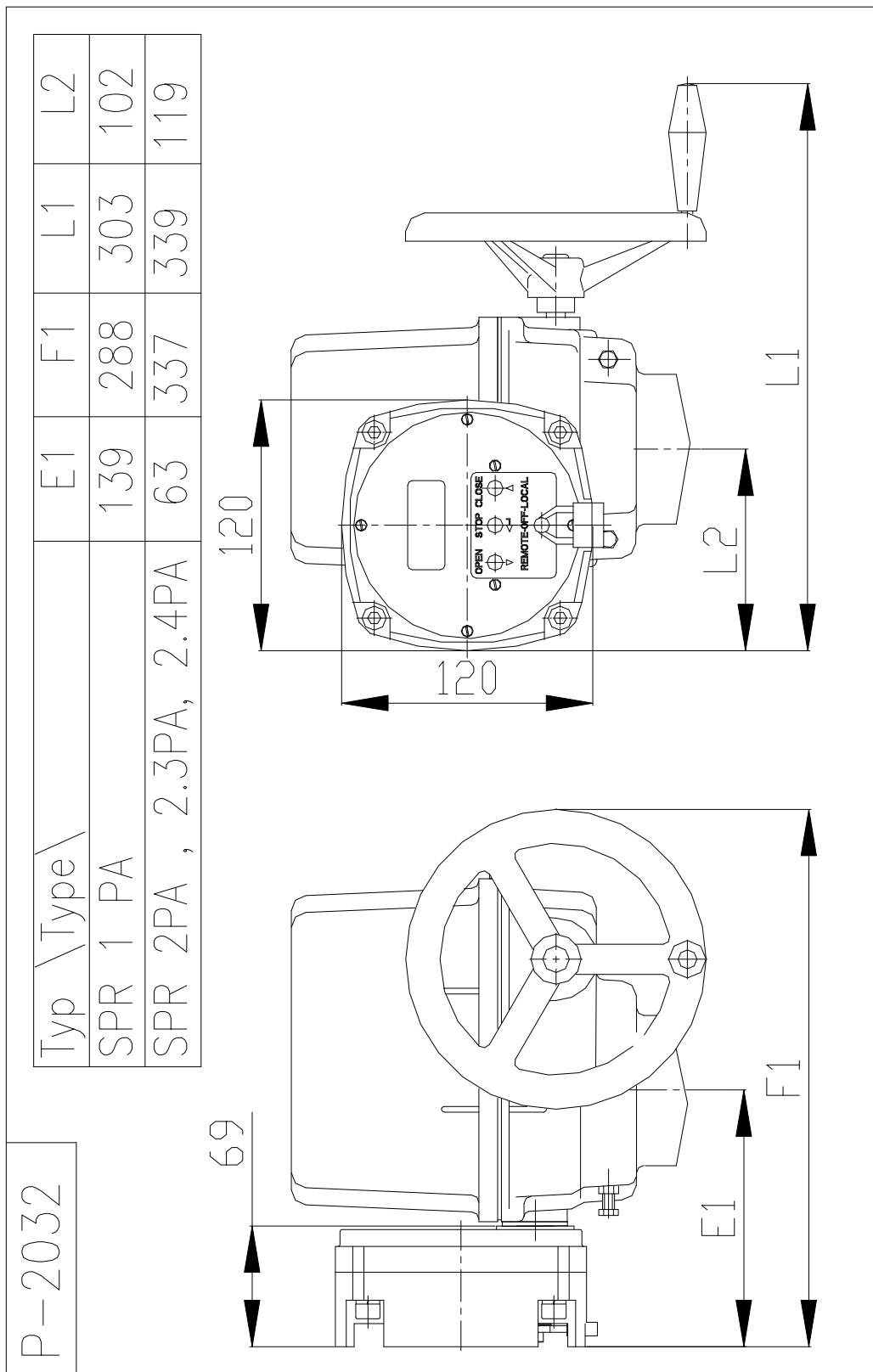

P-xxxx Version EA with local control Modbus/Profibus communication protocol
 (others parameters – see P-1147)

P-2094

| Typ \ Type \ | E1 | F1 | G1 | H1 | L1 | L2 | L3 |
|------------------------|-----|-----|-----|-----|-----|-----|-----|
| SPR 1 PA | 139 | 288 | 246 | 127 | 343 | 102 | 160 |
| SPR 2PA , 2.3PA, 2.4PA | 166 | 340 | 291 | 109 | 381 | 119 | 185 |

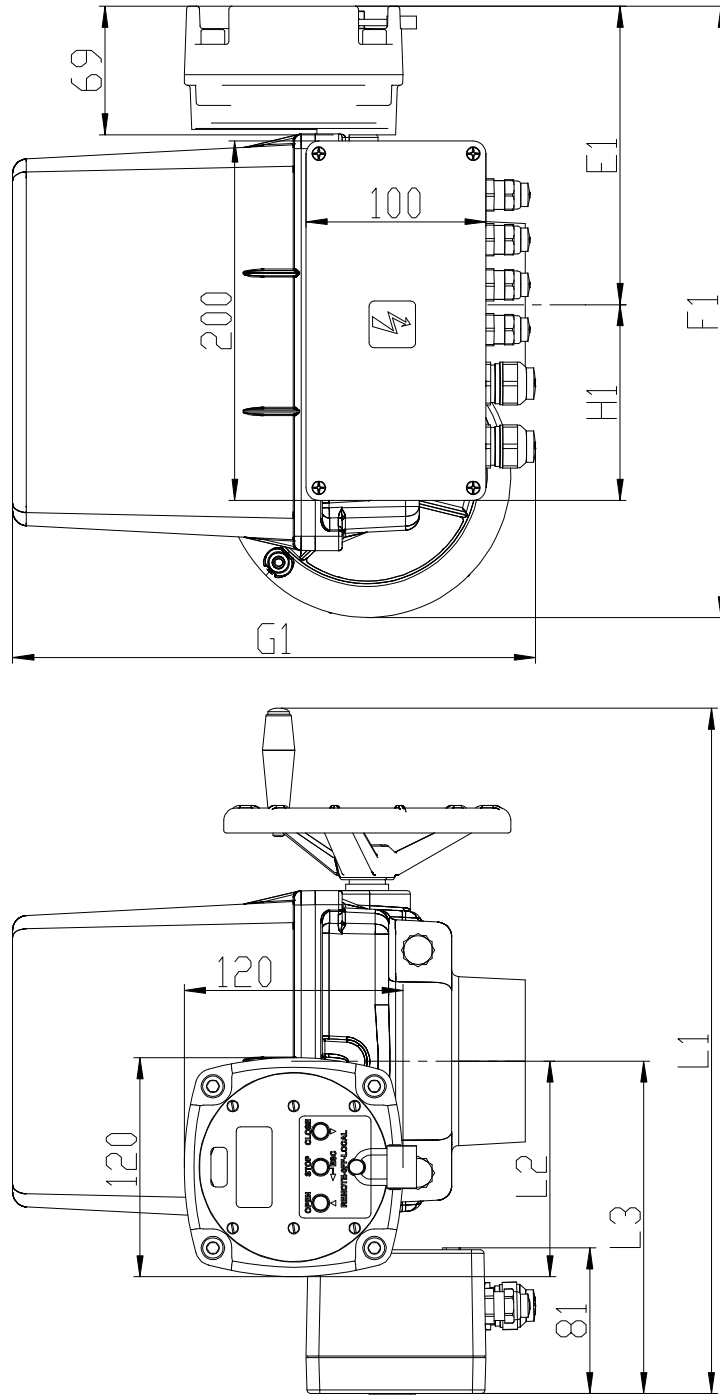

P-1162 Stand + large lever

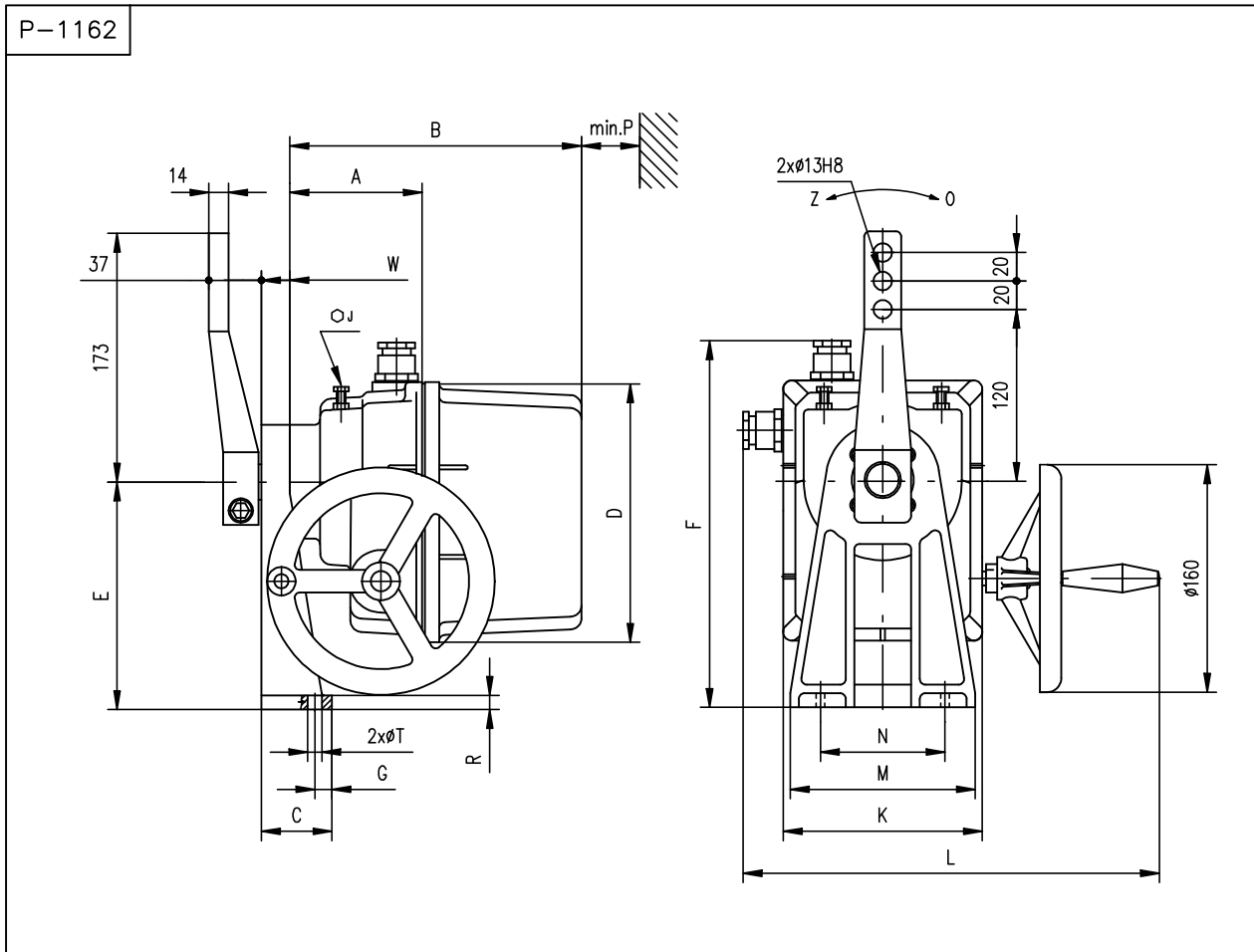

For the EA version with electric local control is valid dimensional drawing P-2032 (other dimensions are identical to P-1162)

P-1395 Stand + large lever

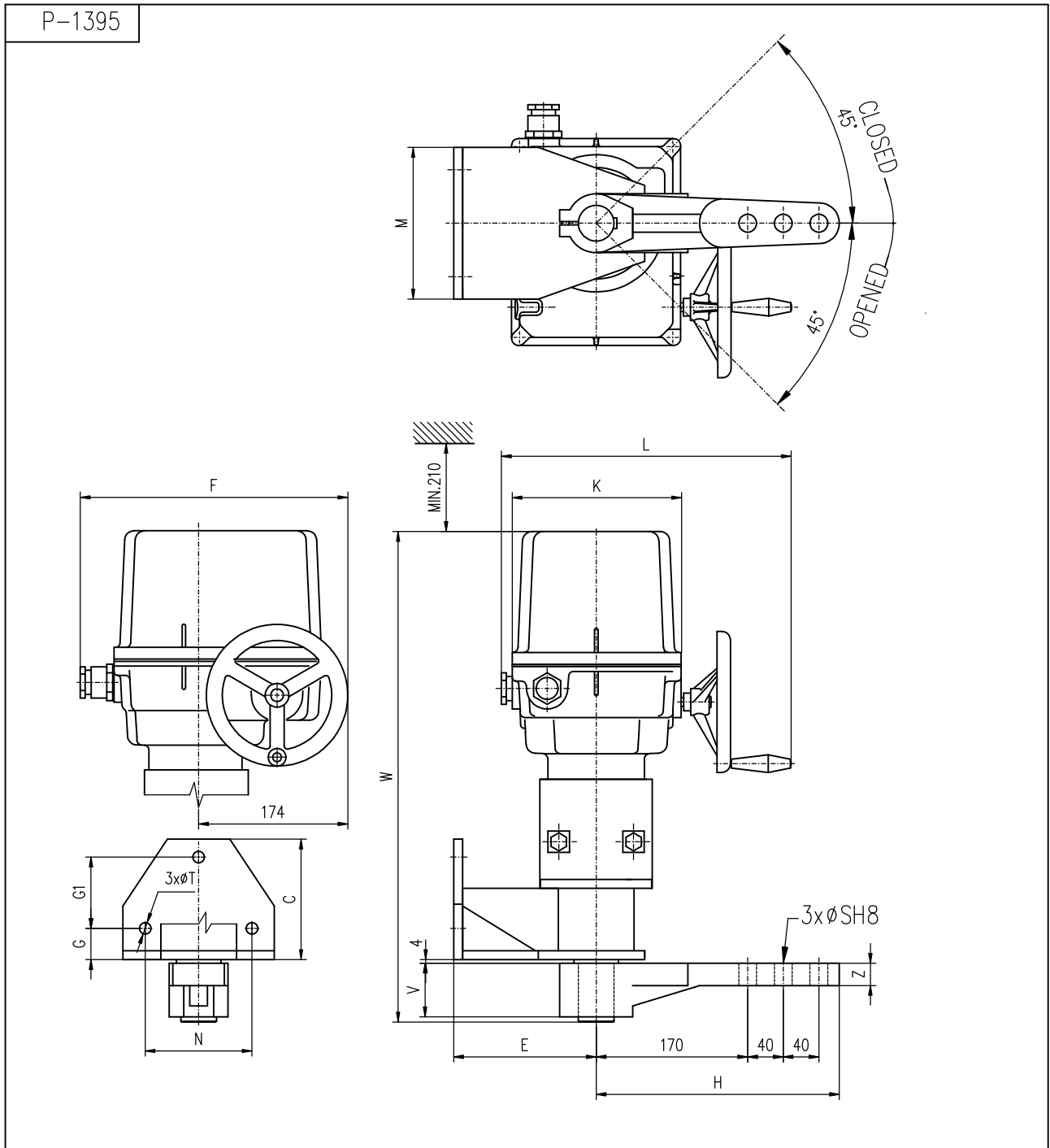

For the EA version with electric local control is valid dimensional drawing P-2032 (other dimensions are identical to P-1395)

DIMENSIONS OF STAND + LARGE LEVER VERSION:

| Type | Drawings | A | B | C | D | E | F | F1 | F2 | G | G1 | H | W | J | K | L | M | N | P | R | S | T | V | Z |
|-----------|----------------|-----|-----|-----|-----|-----|-------------|-----|-------------|----|-----|-----|-----|----|-----|-------------|-----|-----|-----|----|----|------|----|----|
| SPR 1PA | P-1162, P-1225 | 123 | 233 | 50 | 183 | 160 | 258 330* | 169 | 273 345* | 12 | - | - | 20 | 13 | 140 | 276 290* | 130 | 80 | 160 | 10 | - | 10,5 | - | - |
| SPR 2PA | | 132 | 288 | 58 | 232 | 200 | 323 403* | 194 | - | 30 | - | - | 28 | 17 | 190 | 326 351* | 160 | 90 | 210 | 11 | - | 12,6 | - | - |
| SPR 2.3PA | P-1395, P-1412 | - | - | 135 | - | 160 | 297 377* | 194 | - | 35 | 80 | 273 | 532 | - | 190 | 326 351* | 170 | 120 | - | - | 20 | 13 | 60 | 25 |
| SPR 2.4PA | | - | - | 200 | - | 220 | 297 377* | 194 | - | 60 | 120 | 278 | 593 | - | 190 | 326 351* | 228 | 170 | - | - | 25 | 17 | 80 | 30 |

* Note: * - These dimensions are valid for versions with connector.

COUPLING SHAPE:

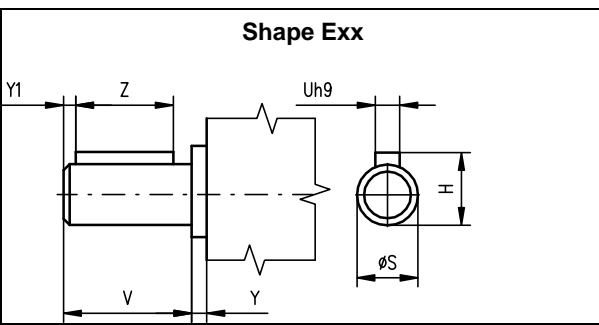
|  | Type | H | S | U | V | Z | Y | Y1 | Coupling shape |
|--|---------|------|----|----|----|----|---|------------|----------------|
| | SPR 1PA | 24,5 | 22 | 6 | 28 | 25 | 2 | 2 | E01 |
| SPR 2PA | 27,9 | 25 | 8 | 35 | 28 | 2 | 2 | E02 | |
| SPR 2.3PA | 43,1 | 40 | 12 | 66 | 56 | 4 | 7 | E03 | |
| SPR 2.4PA | 53,8 | 50 | 16 | 82 | 70 | 4 | 7 | E04 | |

P-0210 Pull-rod TV360

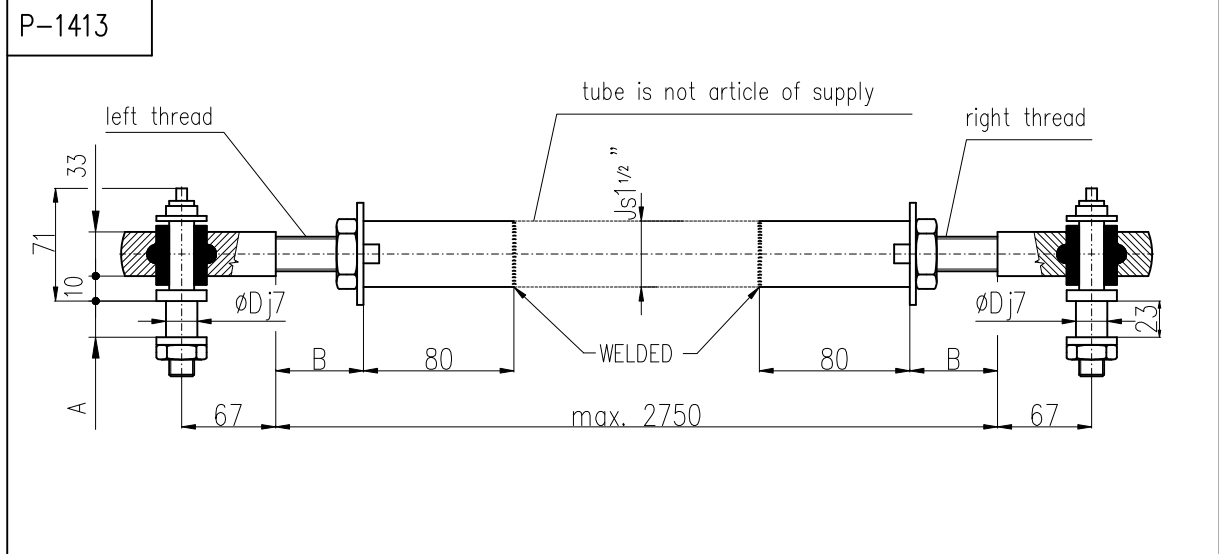
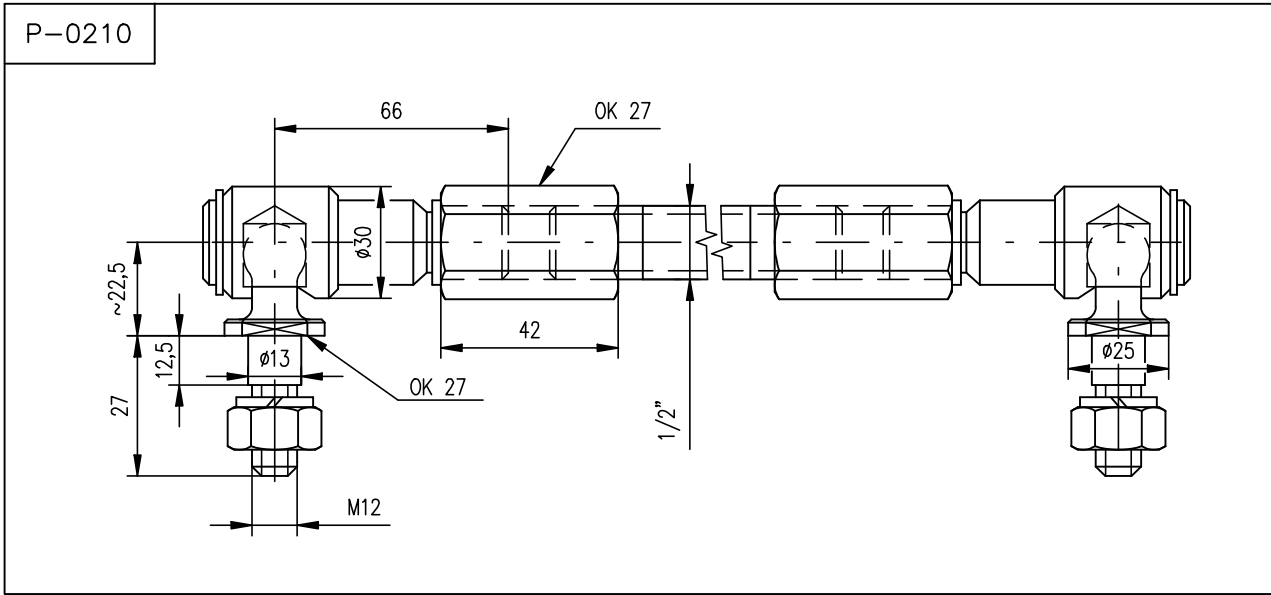

| Version | Pull-rod version | A | B | D |
|----------|------------------|----|---------|----|
| P-1413/A | TV 40-1/20 | 23 | Max.50 | 20 |
| P-1413/B | TV 50-1/25 | 28 | Min. 30 | 25 |

6.8 Guarantee service check report

| | |
|------------------------------|------------------------------------|
| Service center: | |
| Date of repair: | Guarantee repair no.: |
| User of actuator: | Claim applied by: |
| Actuator type number: | Actuator production number: |
| Product claim fault: | Detected product fault: |
| Used spare parts: | |
| Remarks: | |
| Issued on a day: | Signature: |

6.9 Post guarantee service check report

| | |
|--------------------------------|------------------------------------|
| Service center: | |
| Date of repair: | |
| User of actuator: | Actuator operating place : |
| Actuator type number: | Actuator production number: |
| Detected product fault: | |
| Used spare parts: | |
| Remarks: | |
| Issued on a day: | Signature: |

6.10 Commercial representation

Slovak Republic:

Regada, s.r.o.,
Strojnícka 7,
080 01 Prešov
Tel.: +421 (0)51 7480 460,
Fax: +421 (0)51 7732 096,
E-mail: regada@regada.sk

Czech republic:

REGADA Česká s.r.o. (Ltd.) – exclusive representation REGADA, s.r.o. (Ltd.) for sale of electric actuators

Regada Česká, s.r.o.
Kopaninská 109
252 25 Ořech
PRAHA – západ
Tel.: +420 257 961 302
Fax: +420 257 961 301